

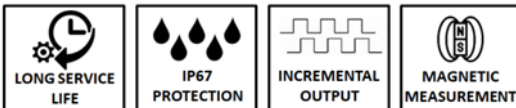

- ✓ **CONTACTLESS AND WEAR-FREE SYSTEM**
- ✓ **HIGH TOLERANCE TO SHOCK AND VIBRATION**
- ✓ **RESISTANT TO DIRT, HUMIDITY AND DUST**
- ✓ **REQUIRES NO CLEANING OR MAINTENANCE**
- ✓ **ROBUST SHIELDED METAL ENCLOSURE**
- ✓ **PROTECTION CLASS IP67**
- ✓ **COMPACT DESIGN**
- ✓ **MEASURING UP to 100m**

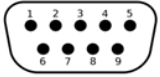

### Technical Specifications

Operating Temperature	- 25 to 85 °C		
Measuring Lengths	100-4000mm ( For more pls ask)		
Protection Class	IP67		
Housing Profile	Anodized Aluminium		
Magnetic Tape	B5 , 5 mm Pole Pitch		
Resolution	5µm, 10µm, 25µm, 62,5µm more		
Travel Velocity	3 m/s max.		
Connection	D-Sub 9 Pin, 5 or 8 x 0,14 mm2 screen cable		
Accuracy	±50µm /m or ±18 µm /m		
Repeatability	± 1 pulse		
			
		<b>SIGNAL</b>	<b>COLOR</b>
		/A	Blue
		0V	Black
		/B	White
		-	-
		/Z	Grey
		A	Yellow
		+V	Red
		B	Green
		Z	Pink
			<b>D-SUB 9 PIN NO</b>
			1
			2
			3
			4
			5
			6
			7
			8
			9

### Electrical Specifications

Power Supply	5 Vdc, +10 Vdc...+30Vdc
Current	50 mA Nominal
Output	TTL, Push Pull Line Driver
Output Signals	A, /A, B, /B, Z, /Z
Output Current	Max. 40mA per channel

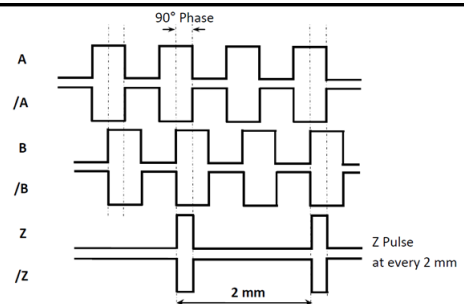

## Magnetic Linear Scale

### Dimensions

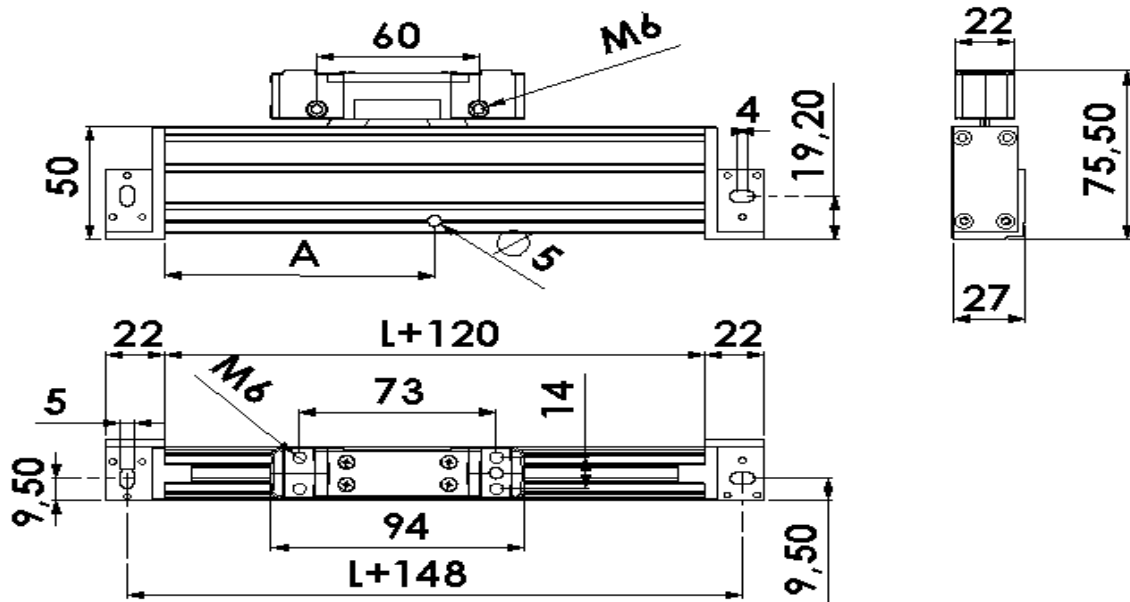

### Installation

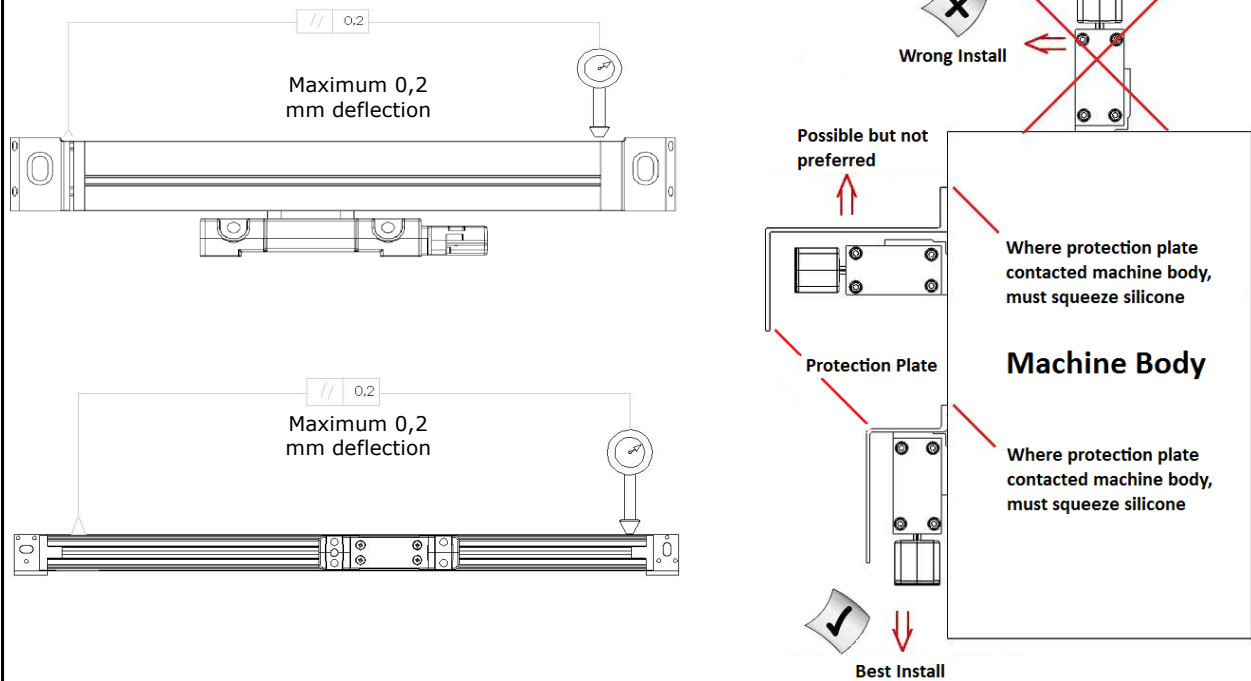

**Trabiss International**  
 Kruiswijk 19P  
 1761 AR Anna Paulowna, Holland  
 Tel : +31 223 523490  
 e-mail: info@trabiss-int.com  
 Web : www.trabiss-int.com

### Distributor

