

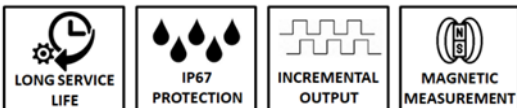

- ✓ **CONTACTLESS AND WEAR-FREE SYSTEM**
- ✓ **HIGH TOLERANCE TO SHOCK AND VIBRATION**
- ✓ **RESISTANT TO DIRT, HUMIDITY AND DUST**
- ✓ **REQUIRES NO CLEANING OR MAINTENANCE**
- ✓ **ROBUST SHIELDED METAL ENCLOSURE**
- ✓ **PROTECTION CLASS IP67**
- ✓ **COMPACT DESIGN**



### Technical Specifications

Operating Temperature	- 25 to 85 °C
Storage Temperature	- 40 to 100 °C
Protection Class	IP67
Casing Profile	Aluminium
Magnetic Tape	B2 , 2 mm Pole Pitch
Tape Reading Distance	1,5 mm
Travel Velocity	3 m/s max.
Connection	D-Sub 9 Pin, 5 or 8 x 0,14 mm <sup>2</sup> screen cable
Accuracy	± 10 µm max.
Repeatability	± 1 pulse

SIGNAL	COLOR	D-SUB 9 PIN NO
/A	Blue	1
0V	Black	2
/B	White	3
-	-	-
/Z	Grey	5
A	Yellow	6
+V	Red	7
B	Green	8
Z	Pink	9

### Electrical Specifications

Power Supply	5 Vdc, +10 Vdc...+30Vdc
Current	50 mA Nominal
Output	TTL, Push Pull Line Driver
Output Signals	A, /A, B, /B, Z, /Z
Output Current	100 mA max. (Every Channel)

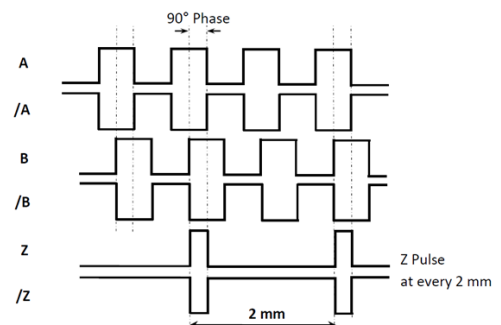

## Magnetic Linear Scale

### Dimensions

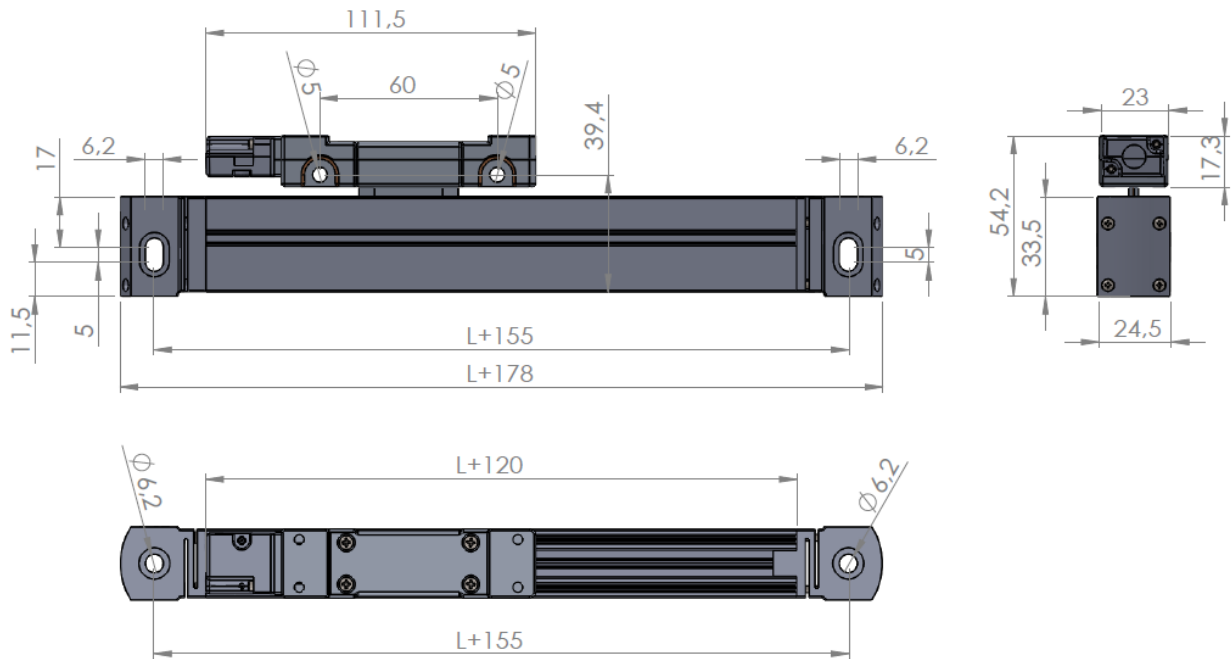

### Installation

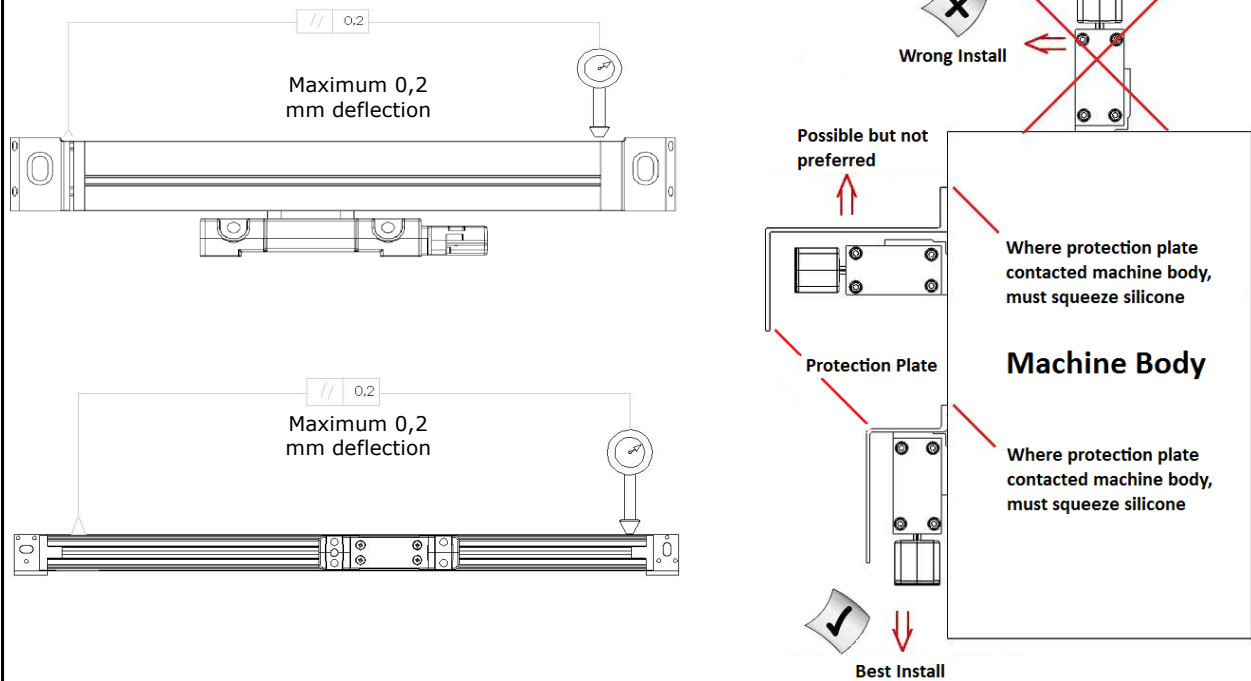

**Trabiss International**  
 Kruiswijk 19P  
 1761 AR Anna Paulowna, Holland  
 Tel : +31 223 523490  
 e-mail: info@trabiss-int.com  
 Web : www.trabiss-int.com

### Distributor

