



MIKRONEL 500 Series



**HIGH PERFORMANCE
DIGITAL READOUT**

**OPERATION
MANUAL**

Ingredients

1. IES DIGITAL READOUT SYSTEMS	3
1.1. IES linear encoder and digital coordinate readout unite usage advantages	3
1. TECHNICAL PARAMETERS	4
2. SYSTEM SETUP	8
3.1. Language Selection	8
3.2. Resolution Setup	8
2.3. Direction Setup.....	9
2.4. Machine Tool Selection.....	9
2.5. Compansation Selection	9
2.6. Advanced Settings	9
2.6.1. Digit On-Off.....	10
2.6.2. Axis Addition.....	10
2.6.3. 4. Axis Type.....	10
2.6.4. Calculator Decimal Setup	10
2.6.5. Probe Logic Level Setup	11
2.6.6. Buzzer Close.....	11
2.6.7. Return to Factory Settings.....	11
2.7. Test	11
2.7.1. Display Test.....	11
2.7.2. Eeprom Test.....	12
2.7.3. Keyboard Test.....	12
2.7.4. CPU Test	12
2.7.5. Relay Test	12
4. Basic Functions	13
4.1. Measurement System Change	13
4.2. Operation Mode Selection	13
4.3. Quick Zero Axis Values.....	13
4.4. Manuel Value Setting for Each Axis:.....	13
4.5. Setting Half Value of The Display Value (Milling, Boring)	14
4.6. Diameter Mode (Lathe):	14
4.7. Center Find (Milling, Boring)	14
4.8. Simple Calculation on Axis Values:	16
4.9. Undo Function	16

4.10.	Activate the 4th Axis	16
4.11.	Display Angle on the 4th Axis	17
4.12.	Sleep Mode:	17
5.	ADVANCED FUNCTIONS	18
5.1.	To Find Zero Point of the Machine Tool	18
5.1.1.	Ruler Zero Point:	18
5.1.2.	Mechanical Zero Point:	19
→	19
5.2.	Error Compensation Function:	20
5.2.1.	Linear Error Compensation Function:	20
5.2.2.	Segmented Error Compensation Function:	21
5.3.	Travel Limit:.....	23
5.4.	Axis Addition (Lathe, Boring).....	24
5.5.	Shrink Function:.....	25
5.6.	Calculator Function:.....	26
5.6.1.	To Transfer the Calculated Values To The Axes:.....	26
5.6.2.	To Transfer The Axis Values To Calculator:	26
5.7.	Datum Point Memory:	27
5.8.	Bolt Hole Circle (Divisor) (Milling)	30
5.9.	Bolt Hole Line Function (Milling)	32
5.10.	Smooth Radius (Milling)	33
5.11.	Simple Radius (Milling).....	36
5.12.	Linear Hole Patterns (Milling).....	38
5.13.	Frame Hole Patterns (Milling)	40
5.14.	Rectangular Pocket (Milling)	42
5.15.	Work Piece Angle Measuring (Milling).....	44
5.16.	Touch Probe (Milling, Boring).....	45
5.16.1.	Zero the Axis / Setting Half Value of the Display Value	45
5.16.2.	Find Center	46
5.16.3.	Measurement	47
5.17.	Tool Diameter Compensation (Milling).....	49
5.18.	Tool Storeroom (Lathe)	50
5.19.	Taper Angle Measurement (Lathe).....	53
5.20.	Digital Filter (Vibration Filter).....	53
5.21.	Inclined Z Axis Machining (Milling)	54
5.22.	EDM Depth Control Function (Erosion)	56
5.23.	HOLD Function.....	58
5.24.	Data Transfer by RS – 232 Port.....	59

1. IES DIGITAL READOUT SYSTEMS

1.1. IES linear encoder and digital readout unite usage advantages

New 2, 3 and 4 axis available MIKRONEL 500 Series Digital Readouts can meet the application in all machine tools with maximum performance and it includes features that are essential for increasing productivity. With high-capacity memory it is possible to save 1000 pcs programs and for the lathes 1000 pcs tool memory. 5 different language choices are existed as Turkish, English, German, Spanish and Portuguese. Connection opportunity by contact probe is also available. With 8+1 digit display and standard resolution values with user designated resolution, MIKRONEL 500 is designed for your all requirements.

New MIKRONEL 500;

- Minimizing production time, increasing productivity.
 - Scrap Cost Saving.
 - More Accurate Positioning.
 - More Quality Parts.
 - 80% Reduced Process time.
 - Amortizing in a Short Time.
-

1. TECHNICAL PARAMETERS

TECHNICAL SPECIFICATIONS	
Axis Number	2, 3, 4
Display	8 Digit + 1 Sign (-) Digit, Green, Touring (-) Sign
Display Resolution	0.1 μm , 0.2 μm , 0.5 μm , 1 μm , 5 μm , 10 μm , 25 μm Or the user can designate as requested.
Input Signal	Available Push Pull or TTL A,B,Z (Line Driver A, B, Z, /A, /B, /Z) Incremental Encoder Signals
Mass	2,7 Kg
Power Supply Voltage	85 – 265 V AC 50/60Hz.
Storage Temperature	- 25 ~ 65 °C
Operation Temperature	-10 ~ 45 °C
Relative Humidity	%20 - %85
Dimensions _(H x W x T)	202mm x 320mm x 84mm
Housing	Aluminum Injection Housing
Diameter Limits	- 99999,999 mm ~ 99999,999 mm

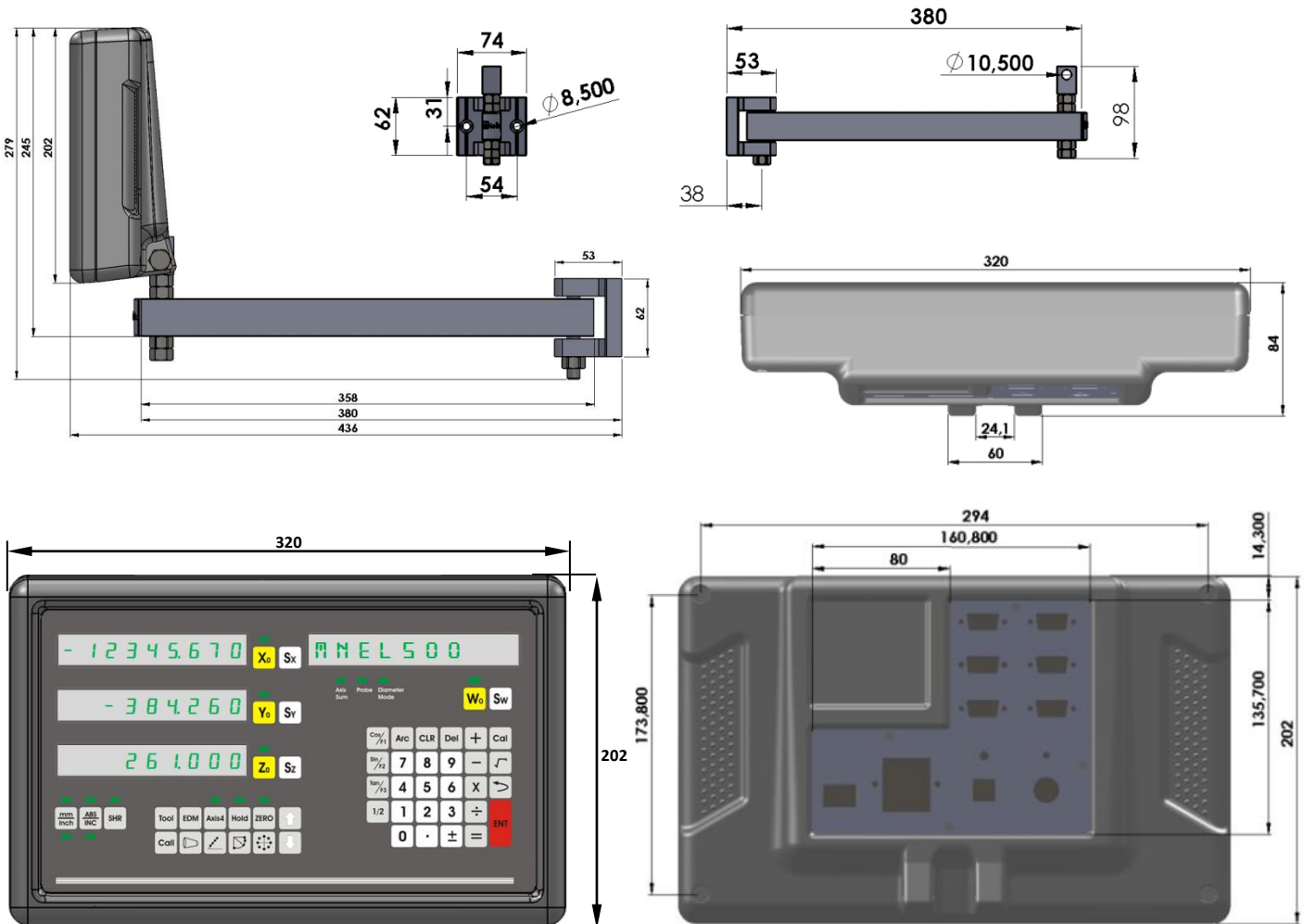

X Axis
(Axis 1)

Y Axis
(Axis 2)

Z Axis
(Axis 3)

Info Screen
and W axis
(Axis 4)



- | | | | |
|-------------------------------------|--|--------------------|----------------------------|
| Metric / Inch measurement selection | Absolute / Incremental Mode Selection | Shrink | Tool Enter Button (Lathe) |
| Screen Renew Ratio and EDM Function | 4 Axis Activation Button | Sleep Mode | User Zeros |
| Recall (lathe) | Trape Angle and Eccentricity Measurement | Bolt Hole Line | Radius Functions |
| Divisor | Travelling Button | | |
| X Axis Selection | Y Axis Selection | Z Axis Selection | W Axis Selection |
| X Axis Zero Button | Y Axis Zero Button | Z Axis Zero Button | W Axis Zero Button |
| 1/2 Function Button | Cosinus Function | Sinus Function | Tangent Function |
| Calculator | Clear Button | Delete | Arc Trigonometric Function |
| Addition | Substraction Button | Multipication | Division |
| Equal | Square Root Button | Undo | Sign Changing Button |
| Decimal Point button | - Numeric Buttons | | |
| ENTER | | | |

WARNING!

While installation of the device please switch all machine energy off and follow the manual directions.

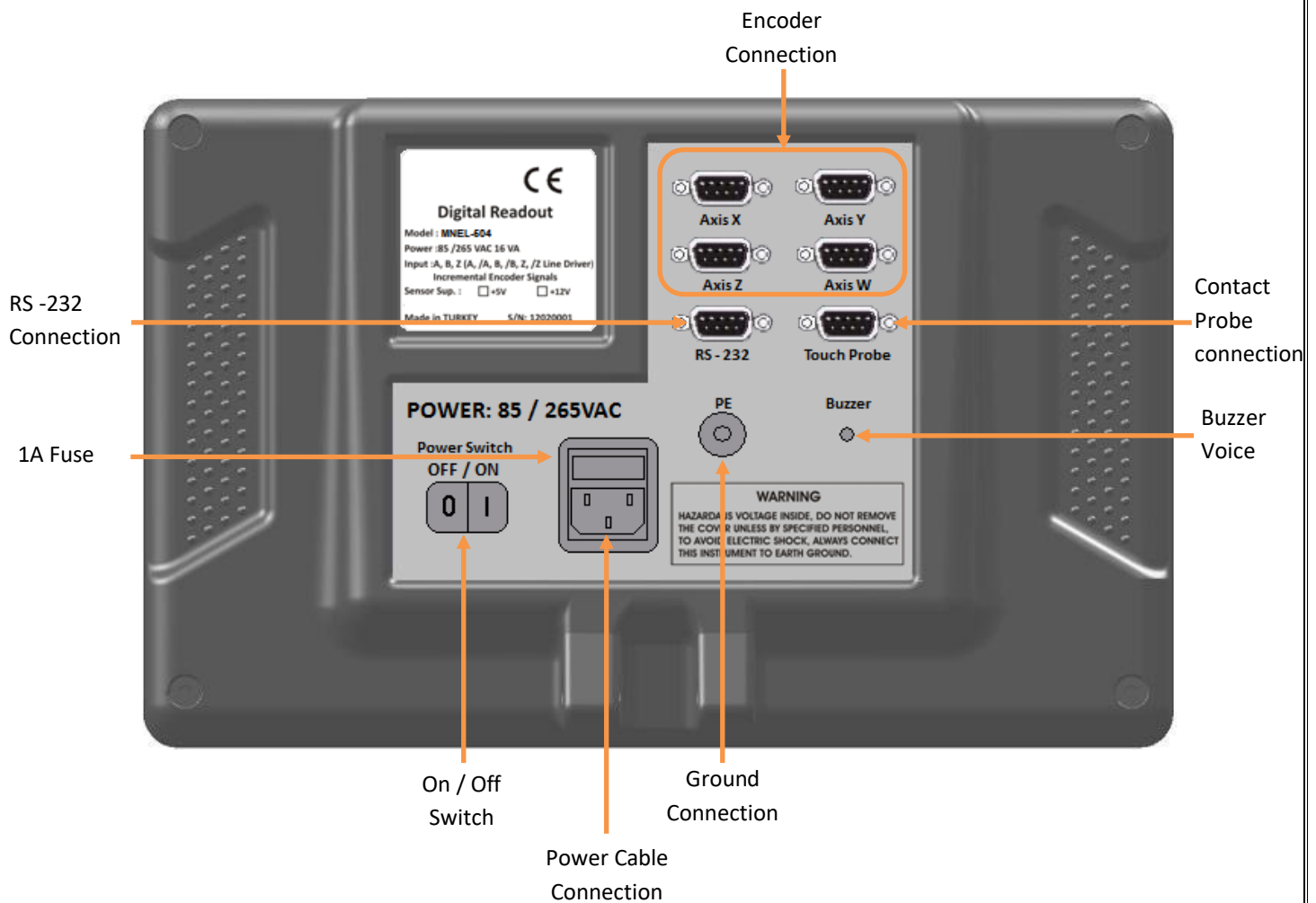

While Connection;

- Never Make Connection Under Energy.
- Check the On / Off Switch is "Off".
- Check the power voltage if convenient values.
- Use only the power cable which is given with the product.
- Check the grounding connections.
- Don't use in strong magnetic field.
- Don't use in high temperature and humidity environments.
- Install the display as vertical in the high which user can use the keyboard and see the screen.

Note: 4 Axis MIKRONEL 504 Type DRO Rear Panel Wiew.

Encoder Connections (Differential)

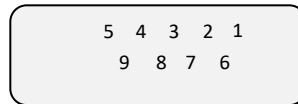

Pin Number	1	2	3	4	5	6	7	8	9
Signal	/A	0V	/B	GND	/R	A	+V	B	R

Encoder Connections

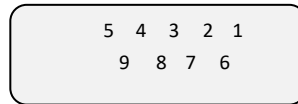

Pin Number	1	2	3	4	5	6	7	8	9
Signal	Empty	0V	Empty	GND	Empty	A	+V	B	R

RS – 232 Output Port Connection

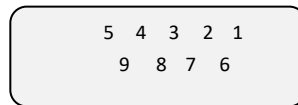

Pin Number	1	2	3	4	5	6	7	8	9
Signal	Empty	Rx	Tx	Empty	0V	Empty	Empty	Empty	Shield

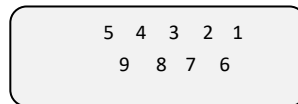

Contact Probe Connection



Pin Number	1	2	3	4	5	6	7	8	9
Signal	Empty+	Empty	+V	0V	Signal-	Empty	Empty	Empty	Shield

Note: While using single contact probe "Signal-" pin must be empty.

2. SYSTEM SETUP

To enter system setup, when MIKRONEL 500 first energized (power connections completed and on/off switch turned “on”) press “ENTER” button () for a while. You will see “LANGUAGE” word as first when you are in system setup menu. For MENU searching   buttons can be used.

3.1. Language Selection

It is the first selection of system setup. The numeric buttons can be used for language selection.



In data display “LANGUAGE” and in X axis display language options are written. Language selection can be done by numeric buttons. After selection please press “ENTER” to save.

Numeric Button	0	1	2	3	4
Language Option	Turkish	English	German	Spanish	Portuguese

3.2. Resolution Setup

After selection language, by pressing  button you can enter the resolution setup for X axis. The included resolution options are displayed as first.



In data screen “RESOLION X” words are seen while the resolution value is seen on X axis. To save the resolutions please press to enter.

Numeric Button	0	1	2	3	4	5	6	7	8	9
Resolution	5 μm	1 μm	2 μm	10 μm	25 μm	0,1 μm	0,2 μm	0,5 μm		*

* “9” button is used for user determinate resolution.



To enter user determinate resolution after pressing “9” button please press “ENTER” button. To enter a value press “Sx” button and enter the resolution value and press enter to save.

You can turn to system setup menu by  button.

For the other axes you can repeat the same operation for resolution setup.

Using 4th Axis For Angle Display

For angle measurement with 4th axis (W axis) when you are in “RESOLION W” please press “9” button and press “ENTER” to enter the pulse number of the encoder. Press “ENTER” again to save. After this in “ADVANCED” menu “W TYPE” option must be select as 1 – rotary. “ADVANCED” menu will be told detailed in the following pages.

2.3. Direction Setup

It determinates the measuring direction according to encoder movement direction.



For positive measuring direction press “1” button. You will see “1” value in X axis. For negative measuring direction, please press “0” button. “-1” value will be seen on X axis. Press “ENTER” to save.

You can repeat the same buttons for the other axes.

2.4. Machine Tool Selection

This menu is used to select the type of the machine tool which Digital Readout used on.



Numeric Button	0	1	2	3	4
Machine Type	Milling	Lathe	Grinding	Boring	Spark Erosion

Please press “ENTER” button after machine tool selection.

2.5. Compansation Selection

Compansation selection is setup by system setup menu.



By up-down button the “COMPNSTN” writing is found please select linear compensation by “0” button and select segmented compensation by “1” button. Save the selected compensation by pressing “ENTER” button.

2.6. Advanced Settings

You can receive to Advanced Settings by “ System Setup” menu.



After seeing “ADVANCED” writing press “ENTER” to enter the menu.

2.6.1. Digit On-Off

It is in the “Advanced Setting” menu.



You can determine the closed digit number by “Hide X” menu . You can close digit numbers up to 5 digits. Please enter the digit number which will be closed by keyboard and press “ENTER” to save

Please repeat the same way for the other axes.

2.6.2. Axis Addition

Only for lathe and boring machine tools the axis addition can be used.

You can use this option by “Advanced Setting”



by“1” button you can active and “0” button you can passive. On lathes it adds and Z axis. On boring machine tools it adds Z and W axis.

In this menu if addition is active, on lathes Z axis , on Borings W axis can't be change by manuel.

2.6.3. 4. Axis Type

The encoder type which will be used on 4. axis means W axis must be enter.

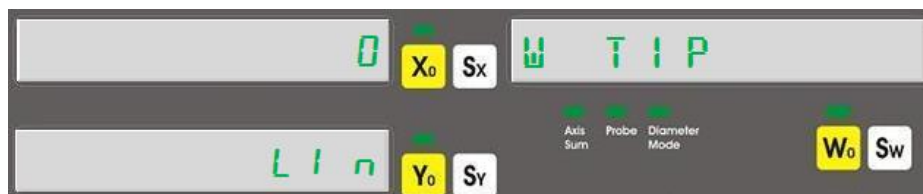

If a rotary encoder will be used press “1” button. On X axis “1” writing and on Y axis “rot” writing will be seen. If a linear encoder will be used “0” button must be pressed. On X axis “0” writing and on Y axis “Lin” writing will be seen.

2.6.4. Calculator Decimal Setup

This menu determines the decimal number of the calculations on the calculator.



3 or 4 digits can be seen after point. The decimal number can be enter by keyboard. After press “ENTER” to save the value.

2.6.5. Probe Logic Level Setup

It can be needed to change according to used probe.

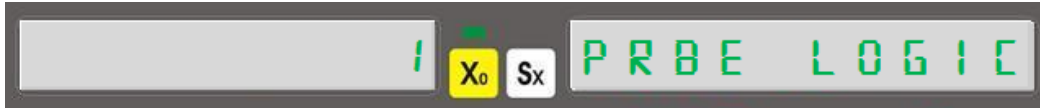

If there is a signal after probe contact (High-Active) must change as "1", if there is no any signal (Low-Active) must be change as "0". Press "ENTER" to save.

2.6.6. Buzzer Close

Buzzer voice can be closed by this menu.



It can be closed by "1" button and can be opened by "0" button.

2.6.7. Return to Factory Settings

It is used to reset all functions changes.



In the menu to return factory settings please press to "Enter" button. "SURE" writing is seen. Press again to "ENTER". "WAIT" writing is seen and after a while it turns to fabric setup.

2.7. Test

In system setup menu the device can be tested. You can make display, eeprom test, CPU test, and Relay Test.



Press "Enter" button to enter the menu.

2.7.1. Display Test

It exist in test menu. It can be active by "ENTER" button.



After pressing "Enter" button it clicks all the LED and display segments. Only "Probe" LED can't be test. To stop the testing press  button.

2.7.2. Eeprom Test

If Eeprom Works correct when you press “ENTER” button you will see “1” writing.



2.7.3. Keyboard Test

It exist in test menu. You can active it by “ENTER” button.



After activation you have to see different number by for each pressed buttons. To turn back press  button.

2.7.4. CPU Test

When you press “Enter” button CPU data can be seen.



On X axis, it shows drawer speed in Hertz unit, on Y axis drawer flash memory in Byte unit , on Z axis RAM in byte unit.

2.7.5. Relay Test

By pressing “Enter” button this test can be done.



For each “ENTER” pressing the relay will be push and pull.

4. Basic Functions

4.1. Measurement System Change

By the button on the keyboard the measurement unit as Metric or Inch system can be selected.

For this operation  button is used. For each pressing the measurement system is changed. The used measurement systems can be transfer to the user by LED's.

Example:

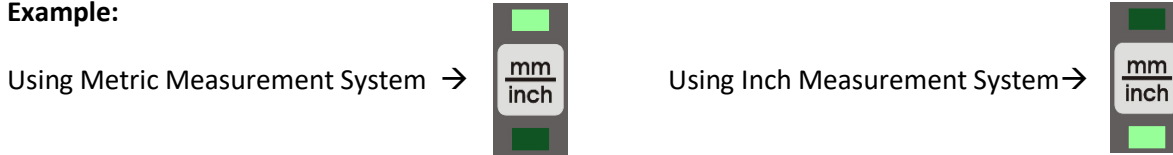

4.2. Operation Mode Selection

Operation Mode can be selected by ABS/INC button on the keyboard. 2 different coordinate display systems are supported.

- Absolute Operation Mode
- Incremental Operation Mode



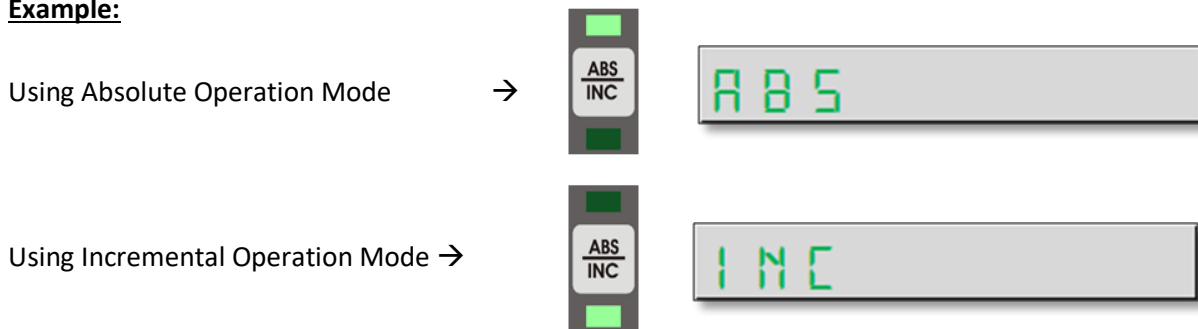

For each pressing the operation mode is changed. The used measurement system is transfer to user by LED's. In the same time it is showed on data display.

Example:



4.3. Quick Zero Axis Values

Axis values can be zero by the zero buttons of the each axes.





To zero X axis  button is used, To zero Y axis  button is used, to zero Z axis,  button is used and to zero W axis  button is used.

Example: To zero X axis;



4.4. Manuel Value Setting for Each Axis:

It is used to setting value to the axes as manuel.

The axis which will be value setting should be selected by the "Axis Selection Button, the value should be set and ENTER button should be pressed. To select X axis  to select Y axis  to select Z axis  and to select W axis  button should be pressed and enter is pressed.

Example: To setting 26.100 mm for X axis;

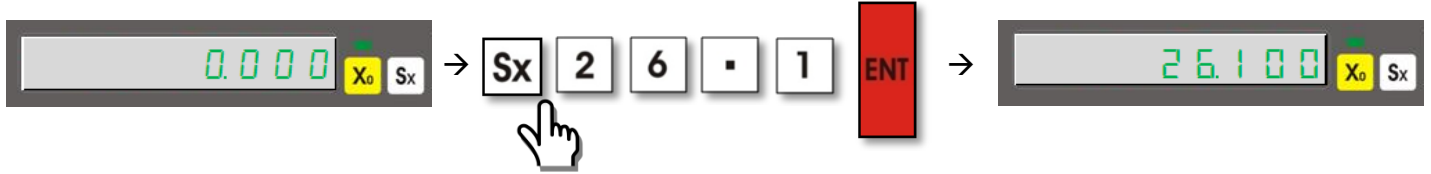

4.5. Setting Half Value of The Display Value (Milling, Boring)

With the included keyboard you can get the half value of the axis you want. Firstly the select the axis which you want to get half value and press 1/2 function button.

Example: To get half value of the X axis which shows 50.000;



4.6. Diameter Mode (Lathe):

With this mode, designed for lathe machines the measured value is showed as 2 times. It is valid on X axis. To activate this function X axis is selected and 1/2 button is pressed. When the function is active "Diameter Mode" LED signs.

Example: On X axis which shows 50.000 value to activate diameter mode;

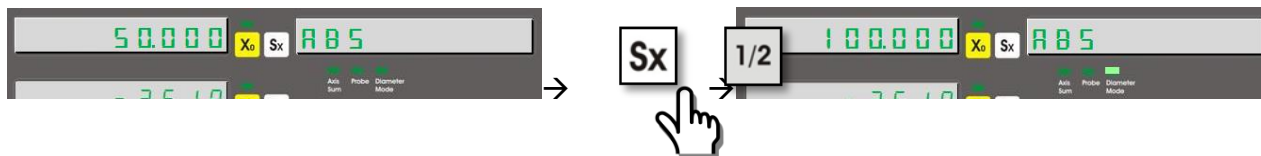

4.7. Center Find (Milling, Boring)

It is used to find centre of the work piece on XY plane according to teached points. The 4 point of the work piece must be teached.

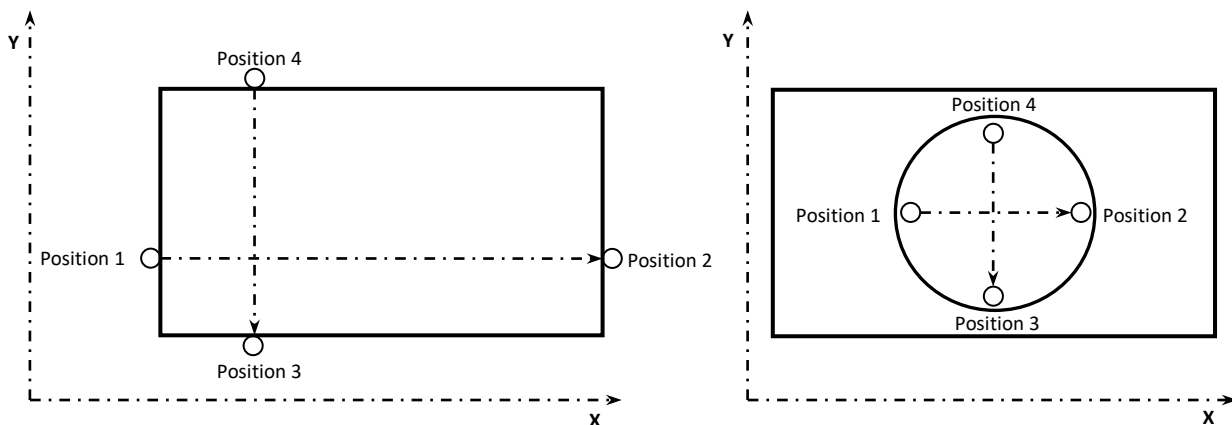

Please press "5" button and press enter to enter the function. Contact the tool edge on the first point on X axis as "Position 1" and press enter to save. Contact the tool edge on Point 2 for position 2 and press enter. For 3 point contact the tool edge to Point 3 on Y axis for position 3 and press enter. As last contact the tool edge for Point 4 and press enter to save. You will see "OK" writing on the screen. When you press enter you will see the coordinates to find the centre by moving. When you move the table up to make zero the coordinates you will be found the centre.

Example:

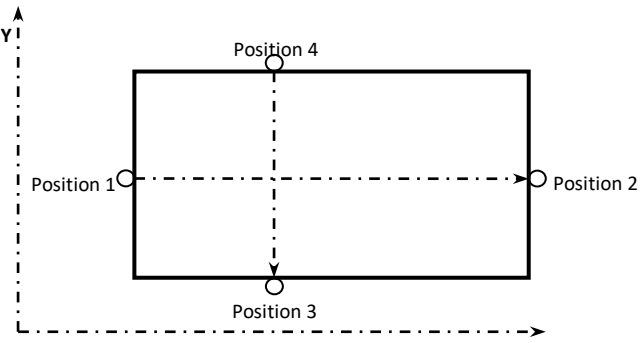

To find the centre of the drawing on the left.

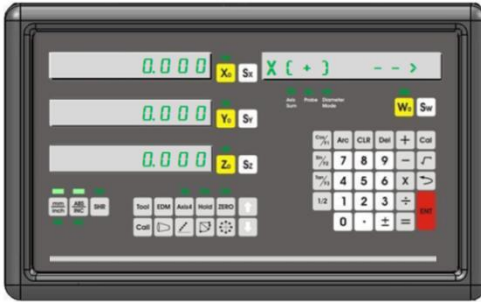

Tool edge is brought to "Position 1"

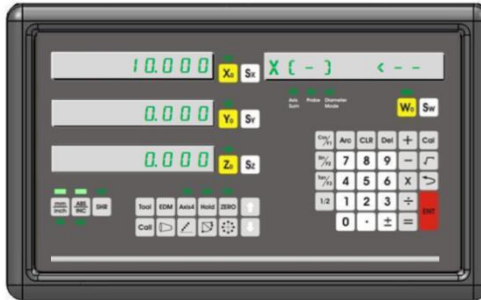

Tool edge is brought to "Position 2"

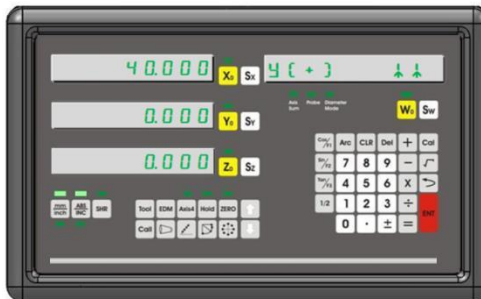

Tool edge is brought to "Position 3"

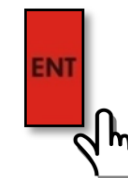

Tool edge is brought to "position 4"

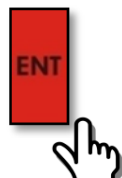
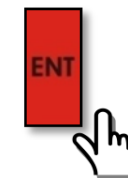

→ When you move up to reset axis value zero you can find the centre of the work piece.



4.8. Simple Calculation on Axis Values:

It is possible to make simple calculation as addition, subtraction, division and multiplication on axis values. It can be done without activation of calculator. Firstly the axis which the calculation will be done must be selected. Press the calculation button (+,-,/,*). And then;

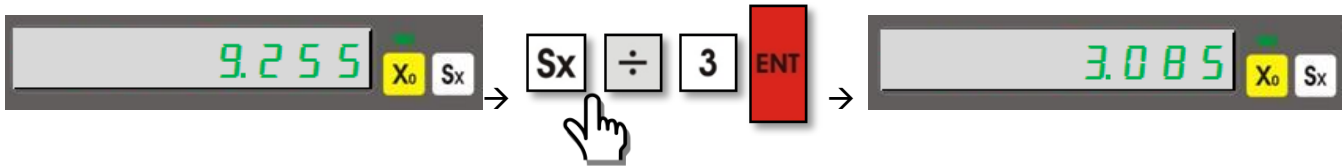
Example: To divide by 3 the X axis value;;



4.9. Undo Function

After transferring the axis value as manual or after making simple calculations to return the last value this function is used. For this function firstly select the axis and press  button and press enter. If you press  button again you will be canceled the operation.

Example: To turn to old values on X axis;

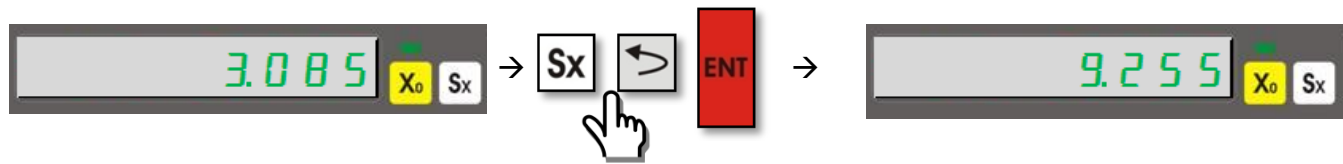

4.10. Activate the 4th Axis

In 4 axis digital readouts you can activate or deactivate the 4th axis. The axis 4 button is used for this operation

Example: To activate the 4th axis;

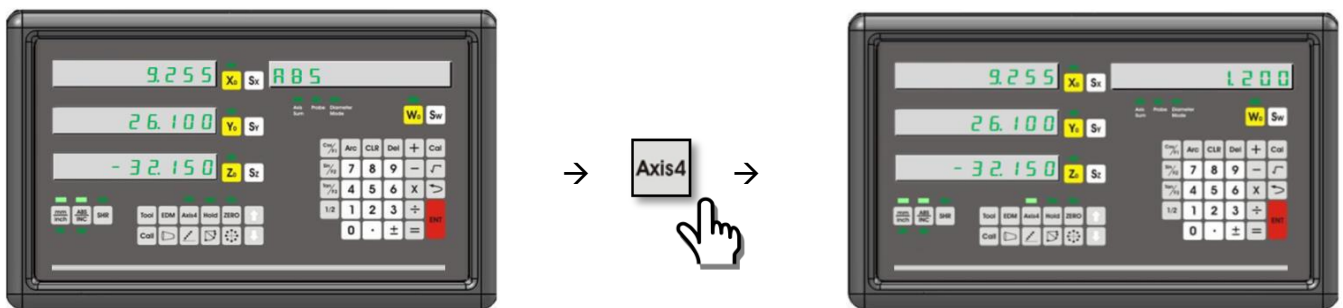

Example: To deactivate the 4th axis;

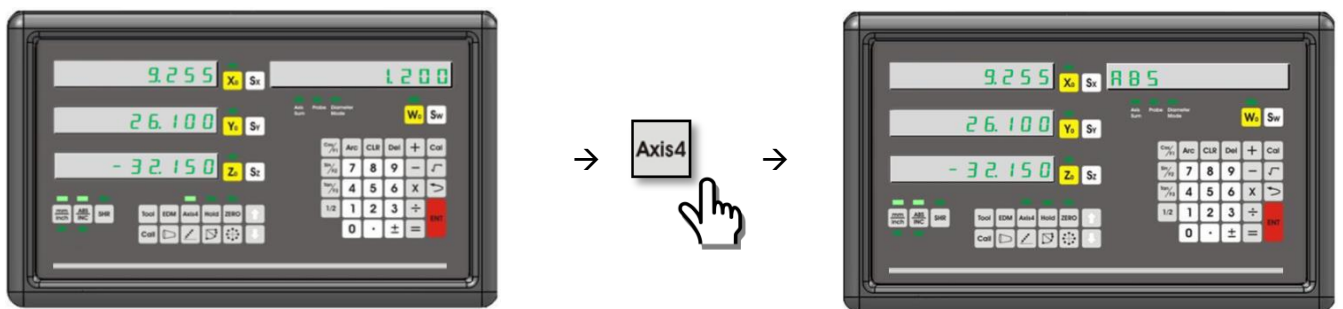

4.11. Display Angle on the 4th Axis

To display angle on 4th axis by “system setting” menu the encoder pulse number must be be entered as W resolution. And again by “system setting” menu, rotary type must be selected. You can also see the this setting on system setting as detailed.

The angle can be set as Degree or Degree.minute.second. To make passing please press “Sw” button and “Tan/F3” button accordingly.

Example: To Change Degree Angle as Degree.minute.second;

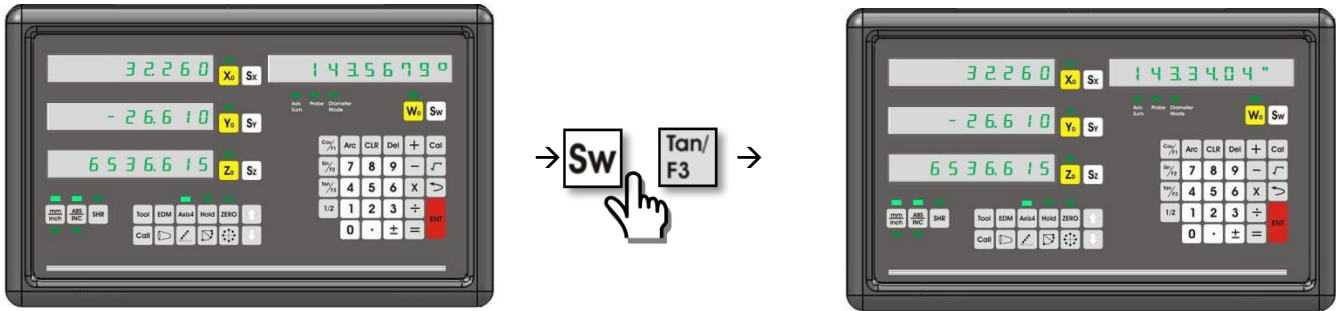

4.12. Sleep Mode:

When the screen is on sleep mode all the buttons are turned off except “HOLD” button. By this way 3th Person interfere will be prevented. Although the buttons are turned off, the signals will be process. If you change the table place it senses this changing and if in the normal mode it use the last position.

In the brake times and after works the device can be sleep mode until beginning to work again.

You can pass “Sleepy Mode” by “HOLD” button and it is possible to exit by the same “HOLD” button.

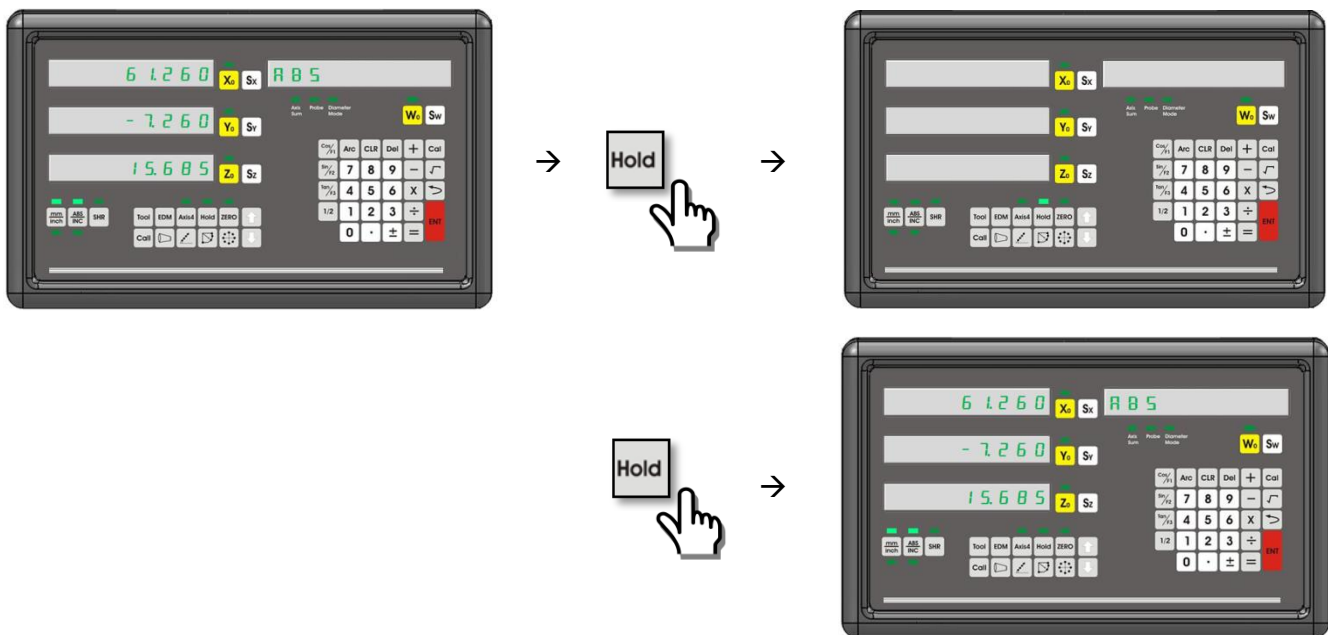

Example: To pass to “Sleepy” mode and to exit;



5. ADVANCED FUNCTIONS



5.1. To Find Zero Point of the Machine Tool

It is used not to lost time by measuring the work pieces one by one. The zero point will not be deleted after energy cuttings. But for the high accuracy it will be better to revise for each new starts.

5.1.1. Ruler Zero Point: To set the ruler zero press the button which selects the axis and press the button . You will see the compensation screen. To pass this screen press  button. On the information Screen you will see the "RULER ZERO" writing. Please press enter and move the scale to see "OK" writing on the screen and you will exit in one second from the function.

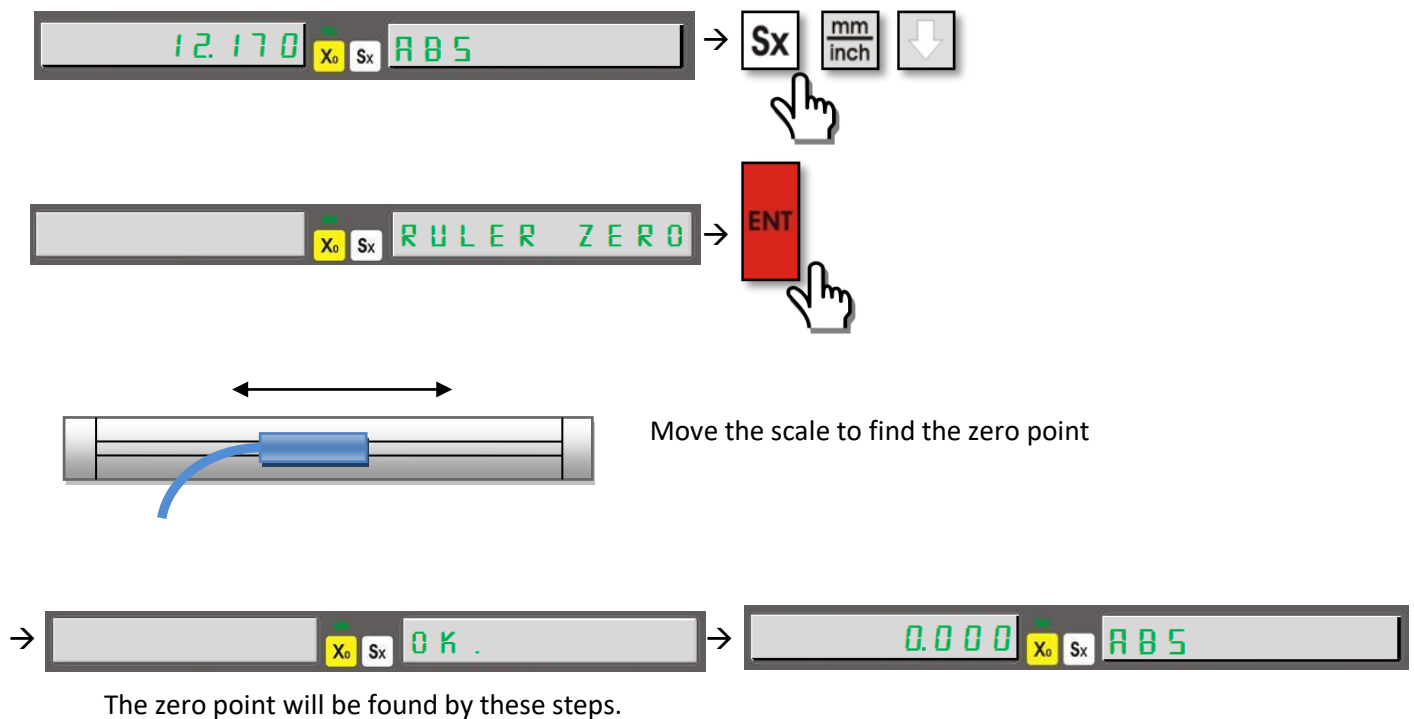
Example: To find ruler zero point on X axis;



5.1.2. Mechanical Zero Point: Please select the axis which will be zero and press  button. You will see the compensation screen. To pass please press  button. When you see “RULER ZERO” writing press “HOLD” button. Then you will see “MACH. ZERO” writing. Move the scale the end point of left side and press “ENTER” to save.

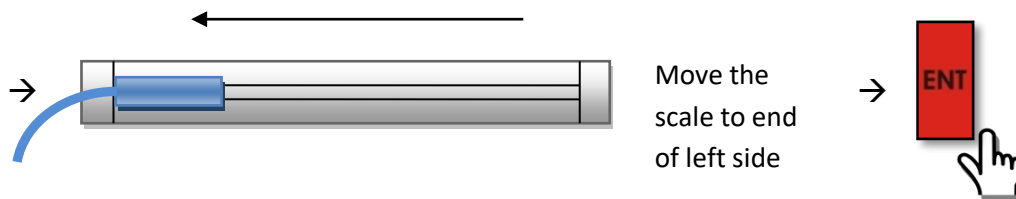

The mechanical zero point will be found by these steps.

5.2. Error Compensation Function:

It is used to compensate the errors on the machine tools. Error compensation function can be used as linear or segmented. You can set this function only in metric system but it can be used both in measuring systems.

5.2.1. Linear Error Compensation Function: Linear Error compensation function can be generate by setting different error values for each axis. The linear errors increase as linear proportion with the distance. In the “System Setting” menu compensation function would be set as “Linear”.

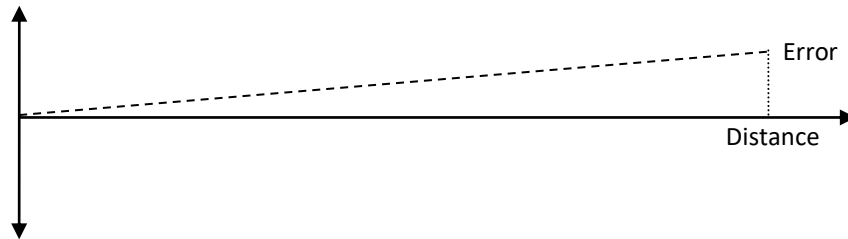

For linear error compensation only one value would be entered as “Correction Factor” to each axis. Affirmation Factor can be calculated according to which value is showed for 1000 mm (1 meter).

$$CorrectionFactor = \frac{\bar{L} \times 1000}{L}$$

L = Real Measured Value
 \bar{L} = Value on the screen

To activate the function, the measuring system must be in ABS mode. Please select the axis and press button. Then please press button enter the Affirmation Factor. To make active the function, measuring system must be in ABS mode. By the axis selection button select the axis and press button. Press enter to button and enter the affirmation factor. Pres enter to save. Press button to exit. To close the linear compensation function repeat same operations and enter the affirmation factor as “0”.

Example: On Y axis the real measurement value is 50 mm but the screen shows 45 mm. To activate linear compensation;

$$CorrectionFactor = \frac{\bar{L} \times 1000}{L} = \frac{45 \times 1000}{50} = \frac{45000}{50} = 900$$

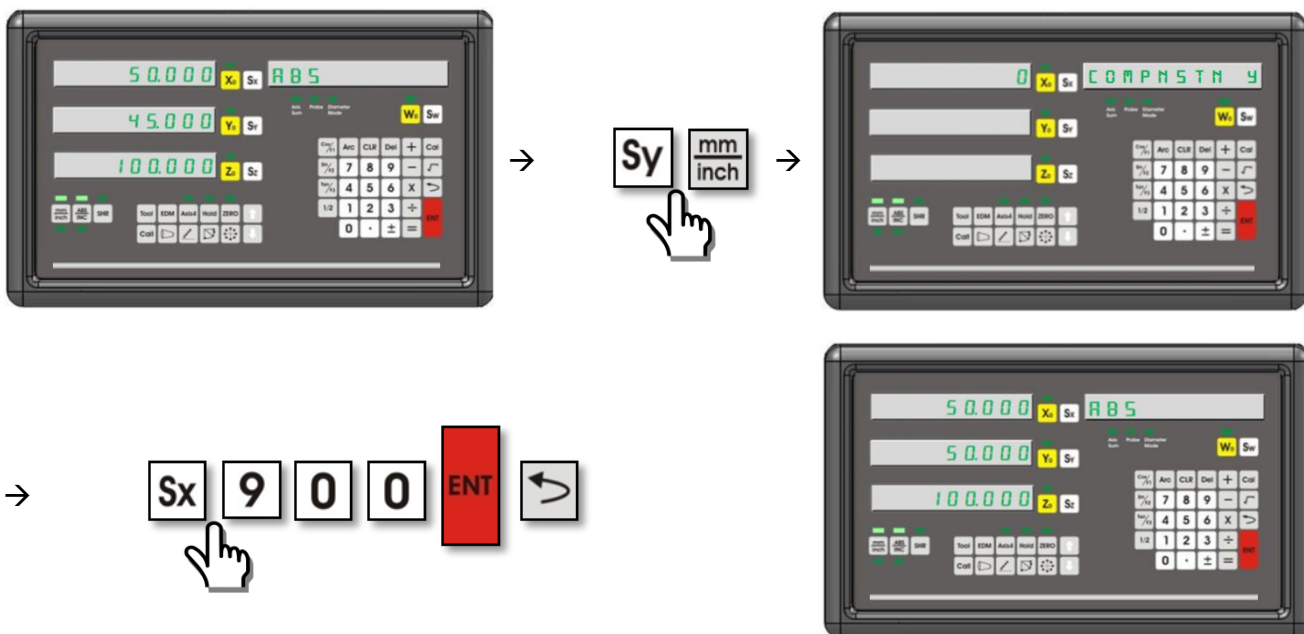

5.2.2. Segmented Error Compensation Function: If the scale makes errors in different dimensions this function is used for compensation. It can make compensation up to 100 point. Please select segmented option from system setting menu.

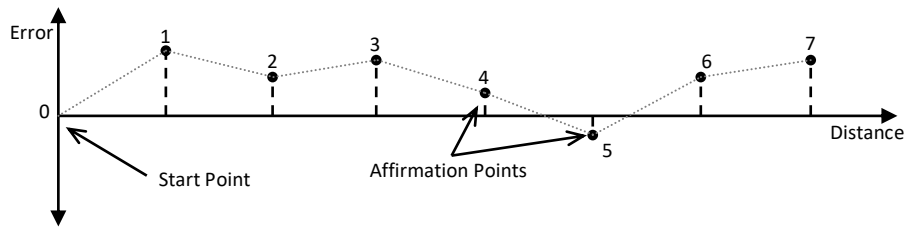

Please move the scale to reference point and enter the points in definite distances.

To make active the function the device must be on ABS mode. The axis which will be correct must be selected and press button. Press Sx button and enter the segment number. Press enter again. Press button for next step. Press Sx button and enter the distance as mm and press enter again to save. Press button for next step.

It is possible to pass this step as two selection. First selection is adjustment of scale zero. To adjust the scale zero when there is writing "RULER ZERO" press enter. By moving the scale please provide to send zero signal to the device. When the zero signal is received the system pass to second step automatically. Second selection is adjustment of mechanical zero point. When there is writing "RULER ZERO" on the screen press "HOLD" button. there will be writing "MACH. ZERO" on the info screen. Move the scale to left end and press enter to save.

After adjustment of scale zero point enter the first correction point. Move the table according to distance which entered before. You will see the error value on the screen. Press Sy button and enter the correct value and press enter to save. After saving the value you will see the error value on the screen again. Pass to 2. Point by button and make the same operations for the other points. After finishing all points press button to exit

Example:

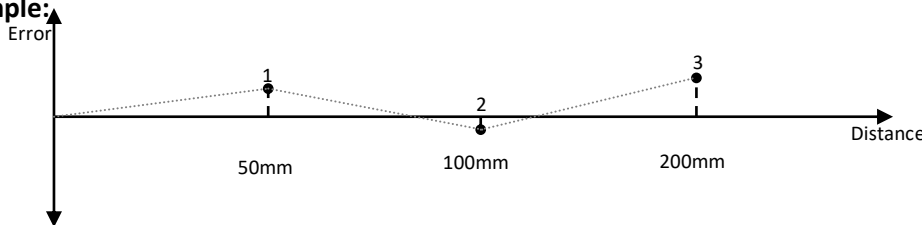

- 1. Point Read Value: 52.285 mm
- 2. Point Read Value: 98.750 mm
- 3. Point Read Value: 154.045 mm

On Z axis the errors are determined with 50 mm distances. To compensate the error;

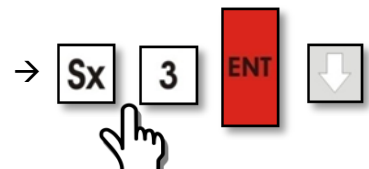

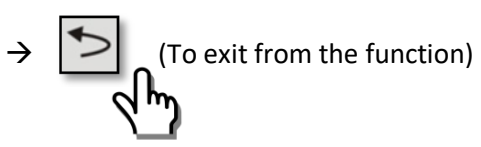
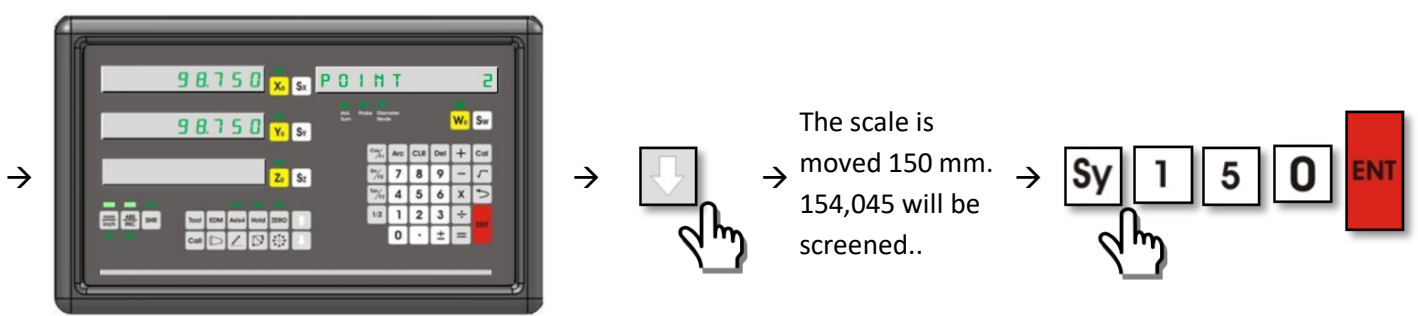
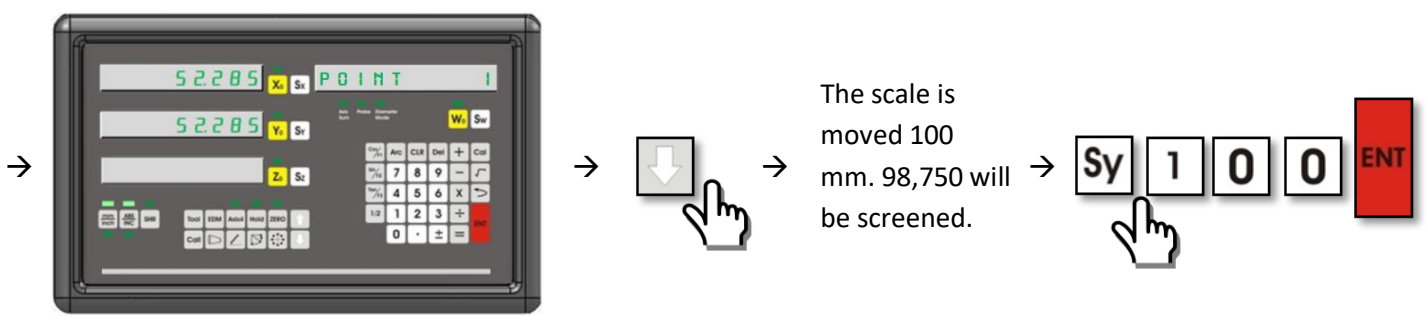
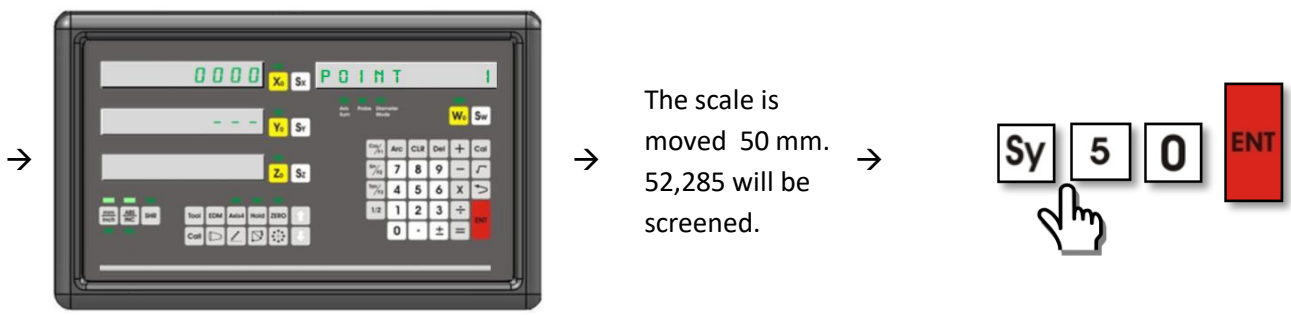
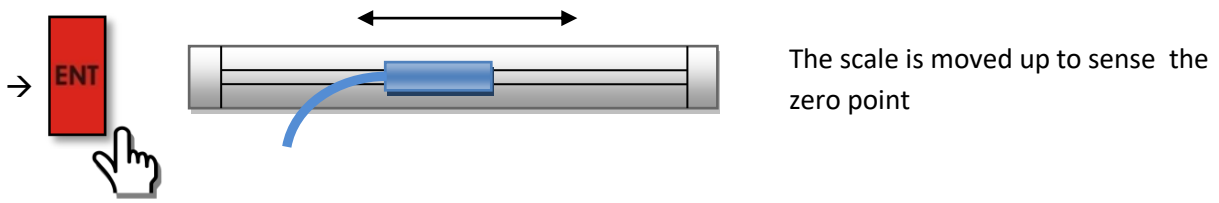
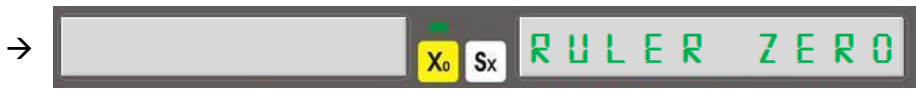

By exiting from the function the segmented error compensation will be active.

5.4. Axis Addition (Lathe, Boring)

Axis addition function is designed for lathe and boring machines. When it is made active on lathe machines it sums the values of Y and Z axis and writes the value on Y axis. On Boring machines it sums the Z and W axis values and writes on Z axis.

To use axis addition function firstly you must make active the axis addition in adjusted functions systems. System setting is clarified on the manual largely.

To open or close the Axis addition function “ARC” button is used. If the Axis addition is active then the “Axis Sum” led will be active too.

Example: On Lathe machine to make active the axis addition function:

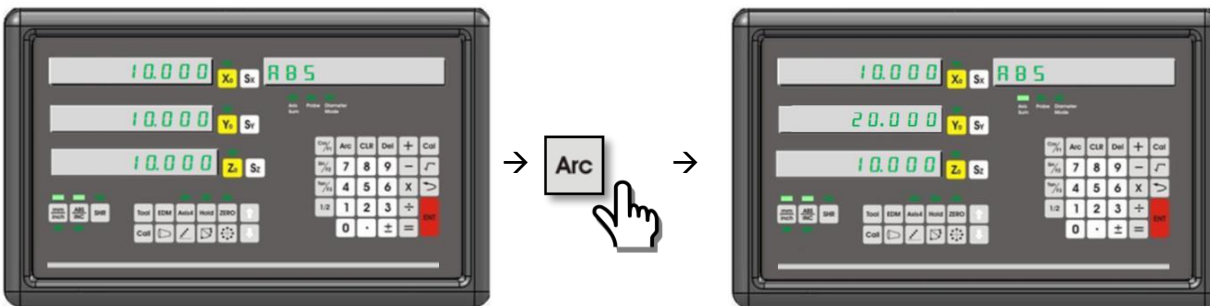

Example: On boring machines to make active the axis addition function:

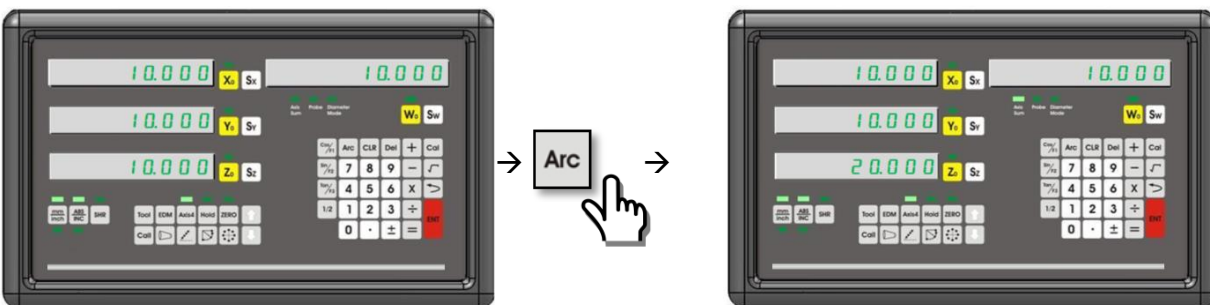

5.5. Shrink Function:

After the injection of the materials as plastic there can be shrink on the dimensions. So the moulding dimensions must be larger in definite ratios. By shrink function you can enter this value to adjust the tolerance. Press “SHR” button and press Sx button and enter the extension ratio by numeric buttons. Press enter to save. To close this function you have to make “1” the extension ratio. It is also possible to close the function by entering “0”, “1”, or pressing Sx and enter without any value. When the function is active the “SHR” led will be signed. For each opening and closing the function please find the zero of the part.

Entered Value > 1: Work piece extends.

Entered Value = 1: Same dimensions.

Entered Value < 1: Work piece shrinks.

Example: To adjust the shrink ratio as 0,005 in plastic injection machines;

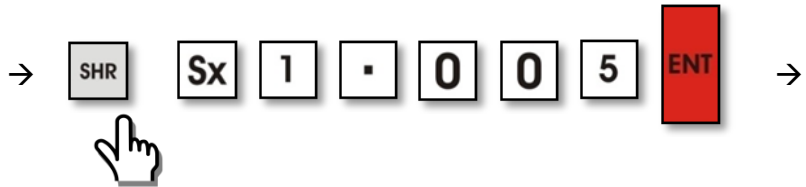

To close shrink function;

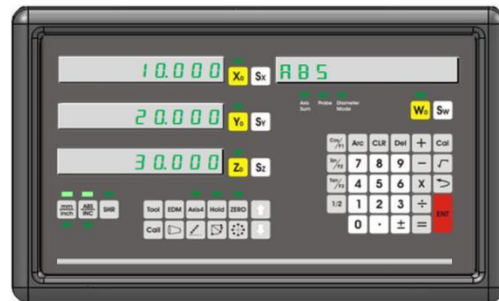
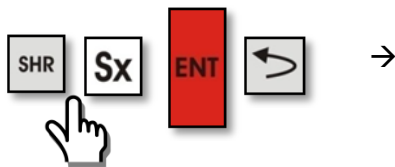

5.6. Calculator Function:

All logical calculations can be done by included keyboard. Near addition, subtraction, division and multiplication also trigonometric functions and sin, cos, tan and square root calculation can be done. Please press "Cal" button to enter or exit to calculator function.

Example: To find square root of 30 number by the calculator;



Example: To divide 25 number by 4 by calculator;

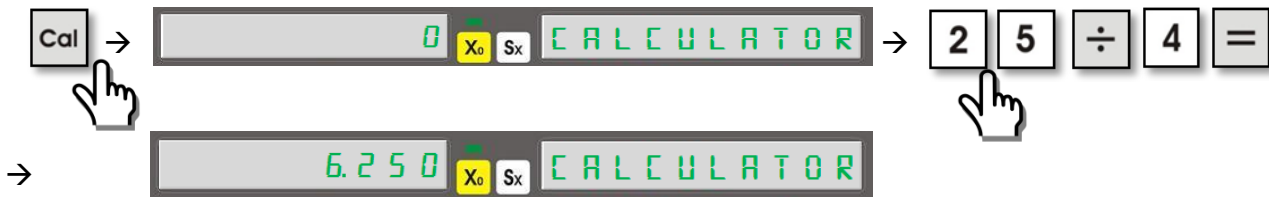

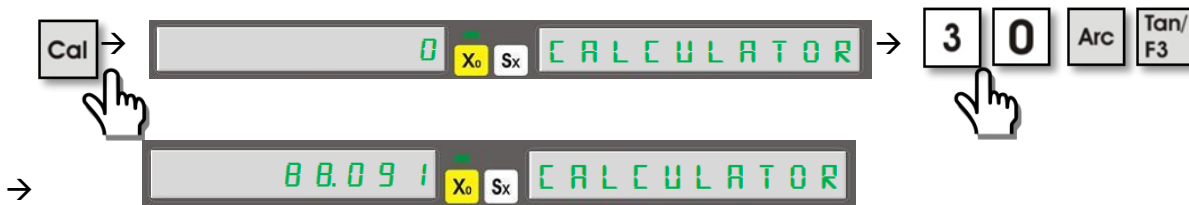

Example: To find "arctan" of 30 number by calculator:

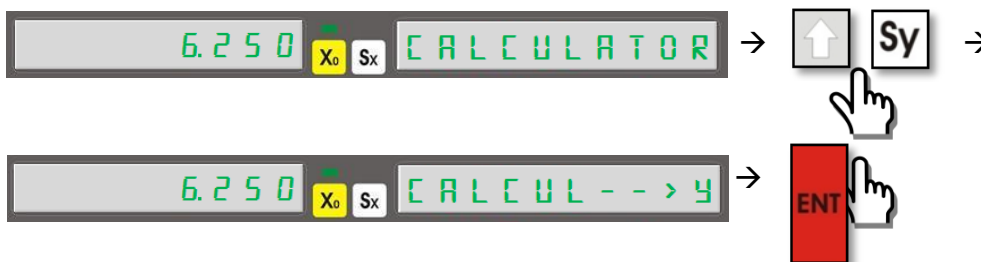

5.6.1. To Transfer the Calculated Values To The Axes: The calculated values can be transfer to the axes. After calculation please press  button and select the axis and press enter. When you exit from calculation function the value will be seen on the axis.

Example: To transfer the calculate value to Y axis:



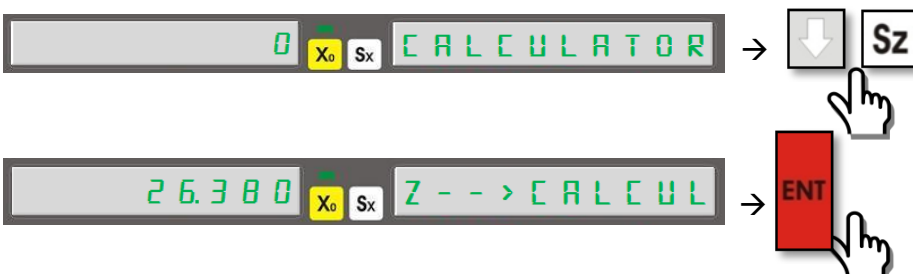

5.6.2. To Transfer The Axis Values To Calculator: To make calculation the axis values can be transferred to calculator. Press "Cal" button to enter the function and press  button and press the axis which the value you would like to deal. When the value is seen press enter.

Example: To Transfer the value on Z axis to calculator;



5.7. Datum Point Memory:

On digital readout display you can save 1.000 different datum point memory. By this way you don't need to set coordinates again and again.

The coordinate axis can be set in memory after moving the machine tablet to definite coordinates. It can be done by two different ways. As first please press  button and enter the coordinate number and press enter to save. Again please press  button to exit. As the second way please press "ZERO" button and enter the coordinate number, after that please press axis zero button. To enter Absolute mode press please press "ABS/INC" button.

Example: X: 26,380 Y: 42,490 Z: -19,345 values are seen on the axes. To set number 50 coordinate memory:

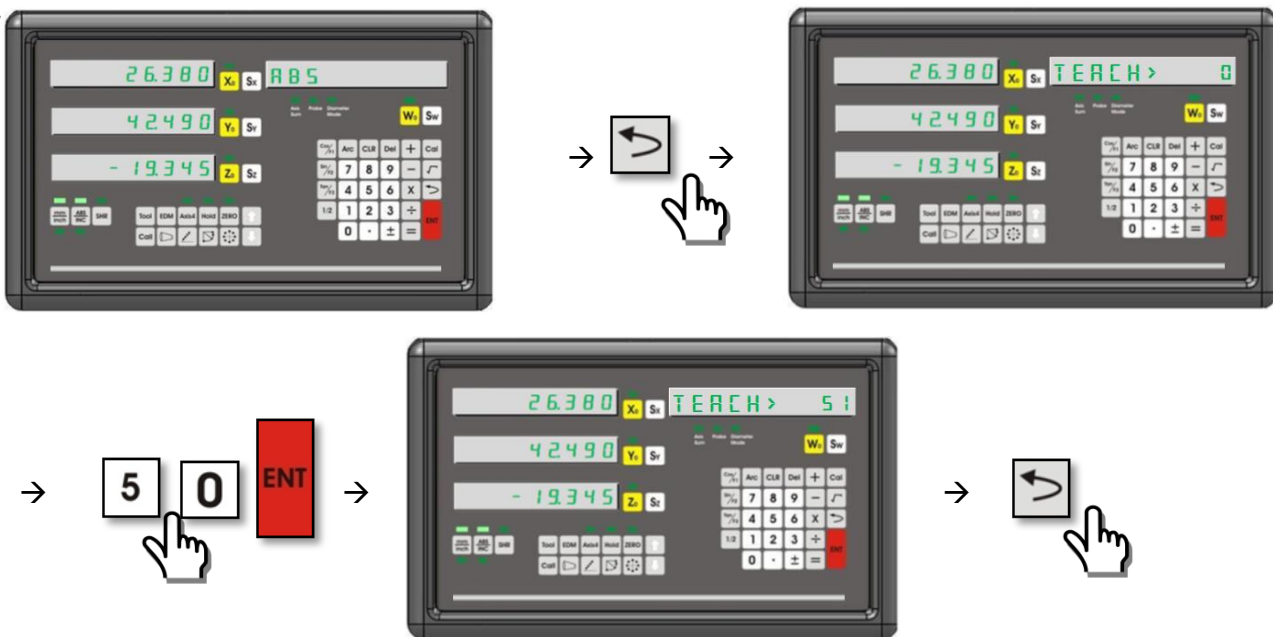

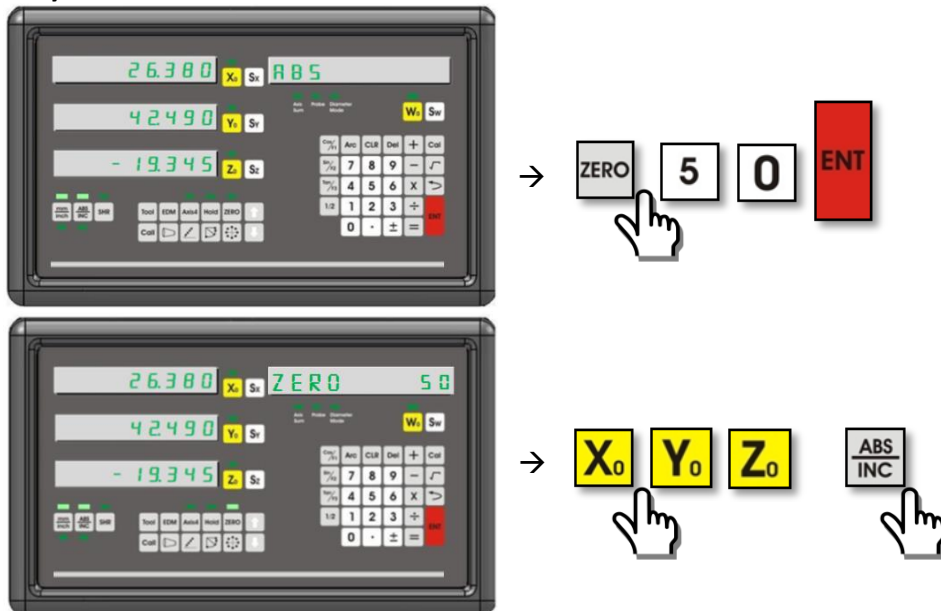

Way 2:



- Also the coordinate memory can be set by manual one by one. To save the coordinate points in memory press "ZERO" button, enter the memory number and press "ENTER". To enter to X coordinate press "Sx", to enter to Y coordinate press "Ys", to enter Z coordinate press "Sx" and to enter Z coordinate press "Sw" button and enter the coordinate value by numeric buttons.

When you are in ABS mode if you press "." button 10 times all coordinate points memory will be zero.

You can receive the coordinate points by   buttons.

The coordinate points in memory get reference the “absolute” operation mode.

Example: In Absolute mode the values: X: 10,000 Y: 0,000 Z: -10,000
 On 10th coordinate point memory X: 20,000 Y: 20,000 Z: 20,000 coordinate points are set;

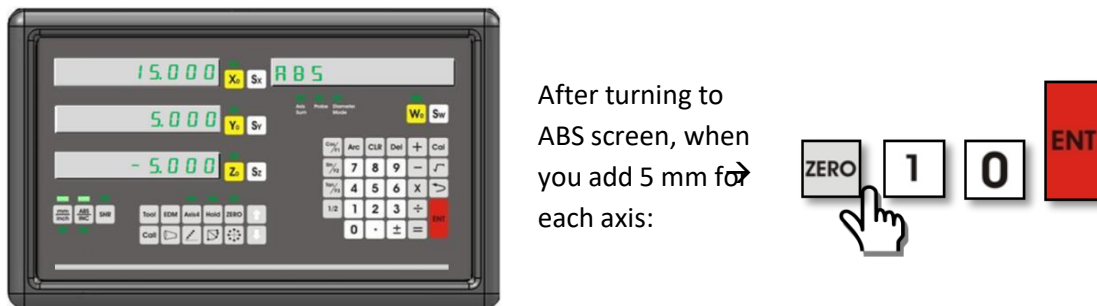
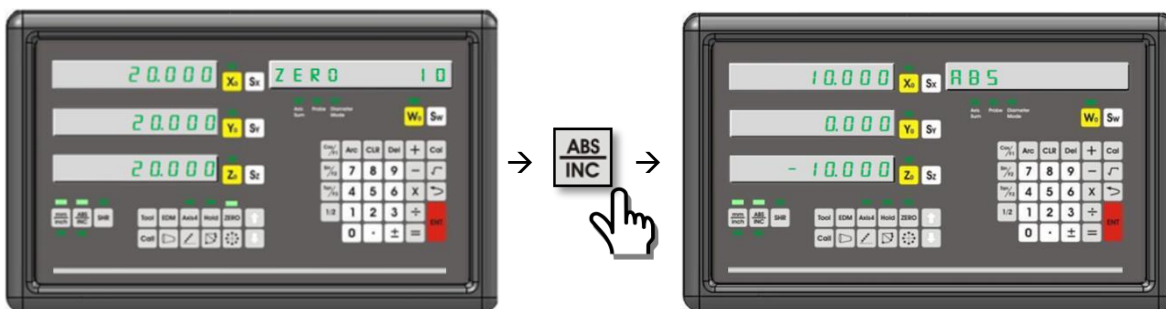
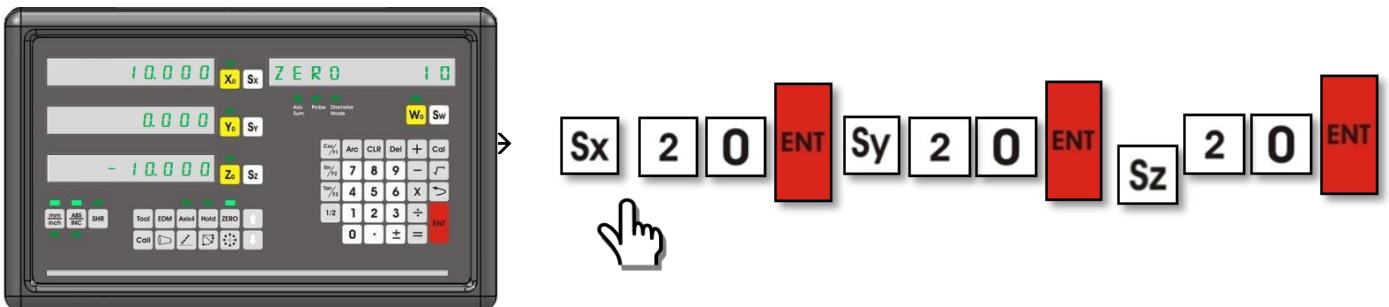

After turning to ABS screen, when you add 5 mm for each axis:



Screen is seen as 5 mm added to coordinate memory values.

Example: X: 5,650 Y: -12,750 Z: 8,225
 X: -2,500 Y: 5,400 Z: 5,000
 X: 9,300 Y: 3,295 Z: -8,755 to add the values to coordinate memory;

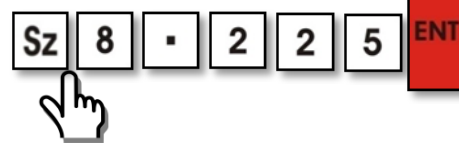
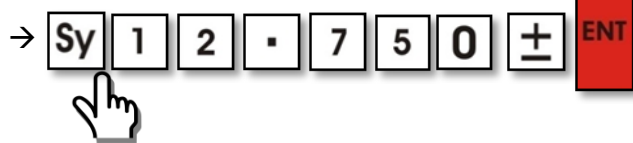
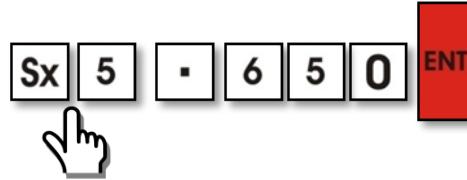
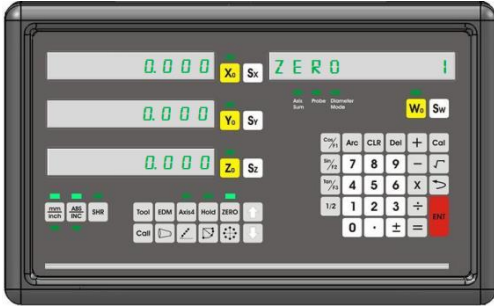
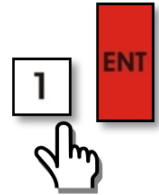
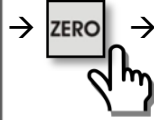
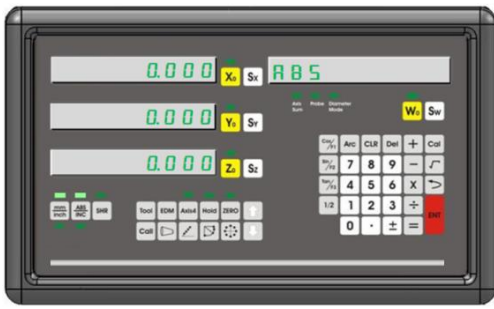

For the other coordinate points, after pressing "ZERO" button the different memory numbers are set, the same things are done.

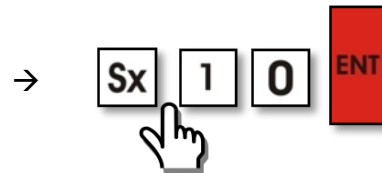
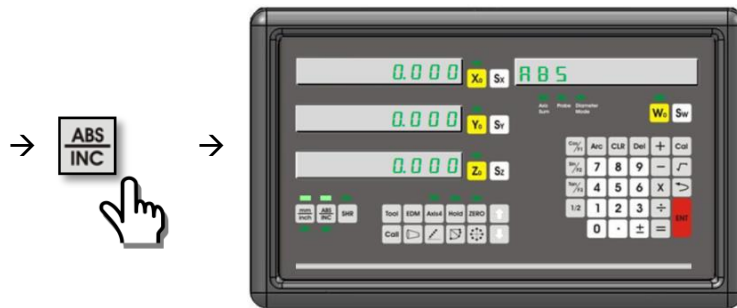







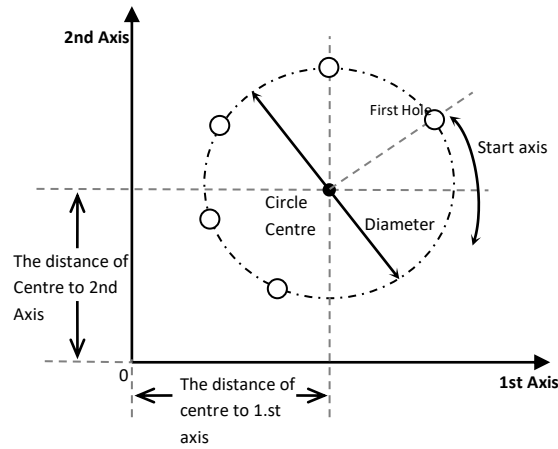



After turning to ABS mode, the changes on X axis are seen on the setted coordinate point. In the example 10 mm is added to X axis so 10 mm will be also added to X axis automatically.

5.8. Bolt Hole Circle (Divisor) (Milling)

Bolt hole circle function is used to hole on the circle with the same distance. The start and finish angle will be determine by the user. When you enter angle value more then 360, system will calculate the value according to 360 degree and make the operation with this value. (Example: when you enter 390 its senses as 30 degree.) Divisor can be done between two axes as you want.



To enter to divisor function  button is pressed. By the   buttons, the operation axes are selected and “enter” button is pressed. The distance between operation axes of circle centre and 0 point are selected and the selection buttons are pressed to enter these values. To pass to following step  button is pressed. This step “Sx” button is pressed and the diameter is set and “enter” is pressed. Please press  to pass the other step. Again press “Sx” button and enter the hole number and press “Enter” again. Again press  and “Sx” button and set the first hole angle and press enter. Press  and “Sx” button again to set last hole diameter and press enter again. To see the distance between the present point and the first hole point, press  button again. To make zero the coordinates as “0,000” move the table. And machine the first hole. By  button the second hole coordinates will be screened. And the same operation will be repeat. After getting all the holes you can exit from the function by the  button.

Example: On XZ coordinate plane ,
 Distance to X axis= 100 mm Distance to Z axis= 80mm
 Circle Diameter= 50 mm
 Hole Number= 3
 Start Angle= 20° Finished Angle= 160°

With these information to use divisor function:

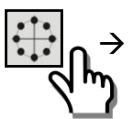
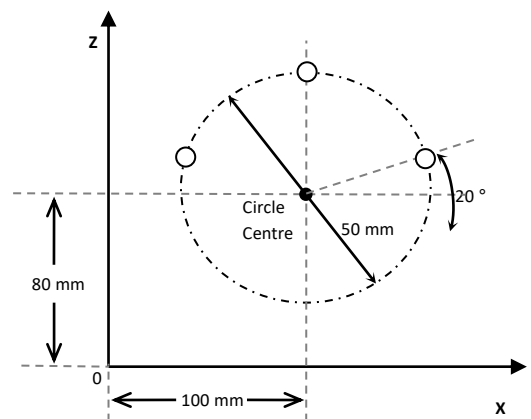

Find “PCD XZ”



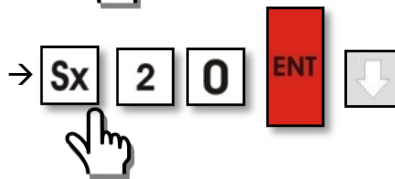
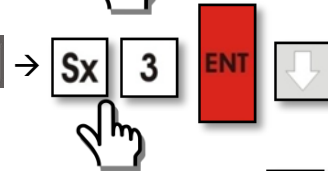
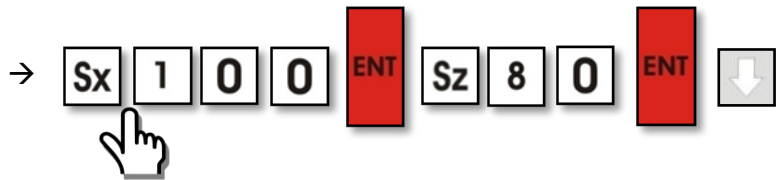

→ To make zero all axis displays the table make move and drilling operation is done. ↓

→ For point 2 the distance values are screened and up to making zero the axis value, the table make moved and the 2. hole drilling operation is done. ↓

→ For point 3 the distance values are screened and up to making zero the axis value, the table make moved and the 3. Hole drilling operation is done. ↶

5.9. Bolt Hole Line Function (Milling)

This function is used to make holes on a line with the equal distances.

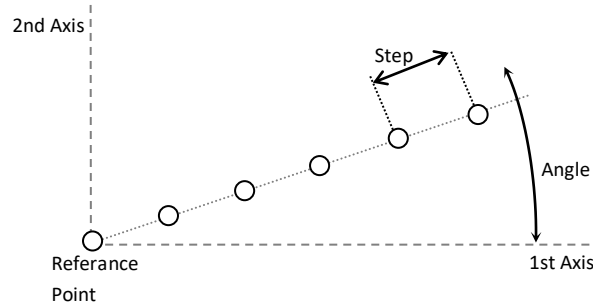

To use this function, the machine tool is moved to reference point which the first hole will be drilled. With the button you can enter the function. With buttons the operation axes are selected and enter is pressed. After this there is two options for user as "STEP" and "LENGTH". User section can be changed with buttons. In the "STEP" section distance between 2 holes and in "LENGTH" section the distance between the first and last hole must be entered. Please select the section and press "Sx". After setting the distance press enter. Press enter again to pass the second step. Press again "Sx" button and enter the angle value and press enter again to save. To pass to the following step press button. Press "Sx" button and enter the hole number. Press enter to save. When you press button you will see the reference point axis values. The value will be 0 because the machine tool is already on reference point. After drilling press button and pass to 2. Point axis values. Move the table up to see 0 values. After drilling press button and repeat the same operations. After the all drilling operations press button to exit.



Example: On XY Coordinate Plane,

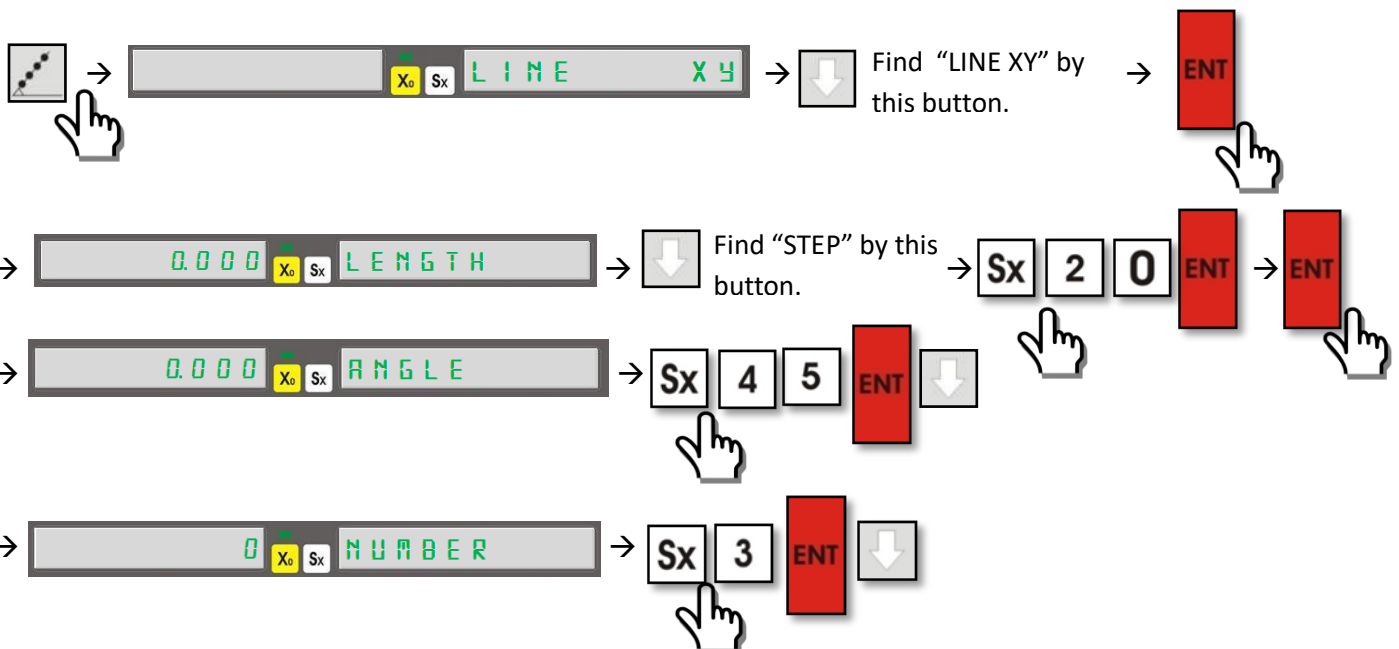
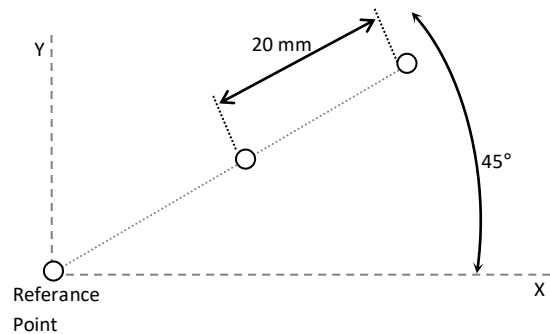

20 mm step distance,

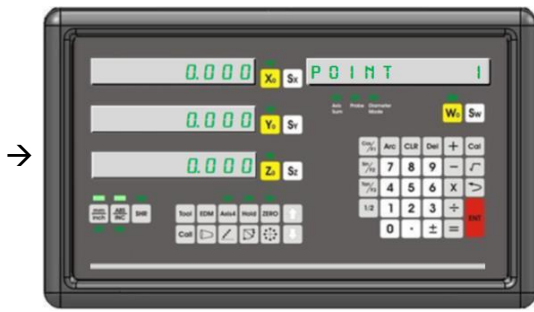

45° Angle, to drill 3 pieces linear holes;





→ Table is on Reference point so all the values are "0" →  

For Point 2 the moving distance is screened. The table is moved up to make zero all axis values and 2nd hole will be drilled. →  

For Point 3 the moving distance is screened. The table is moved up to make zero all axis values and 3th hole will be drilled. →  

5.10. Smooth Radius (Milling)



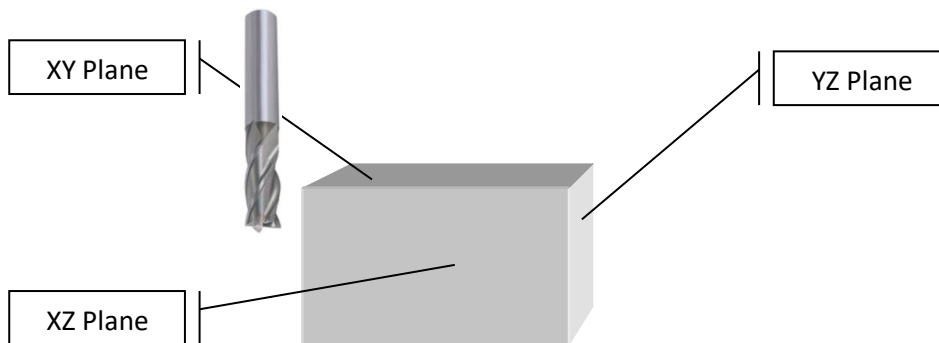

This function is used to accurate circular cutting operation. In this operation the user determines the start and finish angle. This function provides accurate operation and also it provides better time and decrease the scraps amount

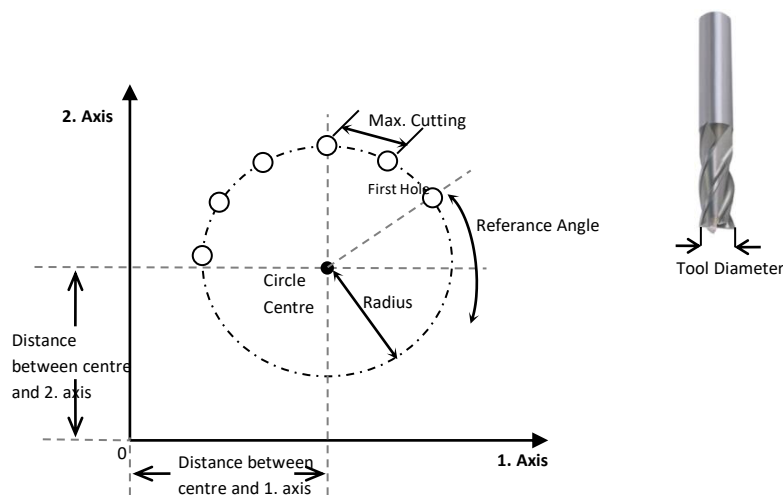

While the radius operation if the arch includes 90° or the multiplies of spherical tool must be used.

To enter to "Smooth Radius" function please press  button and find  button to see "RADIUS" writing on the screen. And press "enter" to enter the function.



By   buttons the axis which the radius will be done, must be selected. Press enter. Press axis selection buttons to enter the distance of axis to centre and press enter. By  button following step is passed. Press "Sx" button and enter the radius and press enter to save. Again press  button and press "Sx" button to enter the cutting tool radius. Press enter to save. Press  button and press again "Sx" button. Enter the maximum

distance between 2 points as “maximum cutting”. Press enter to save. Press button and press “Sx” again. Enter the reference angle and press angle to save. Press button and press “Sx” button and enter the finish angle. Press enter to save. Press to pass following step. In this step you can add or subtract the tool diameter from radius.

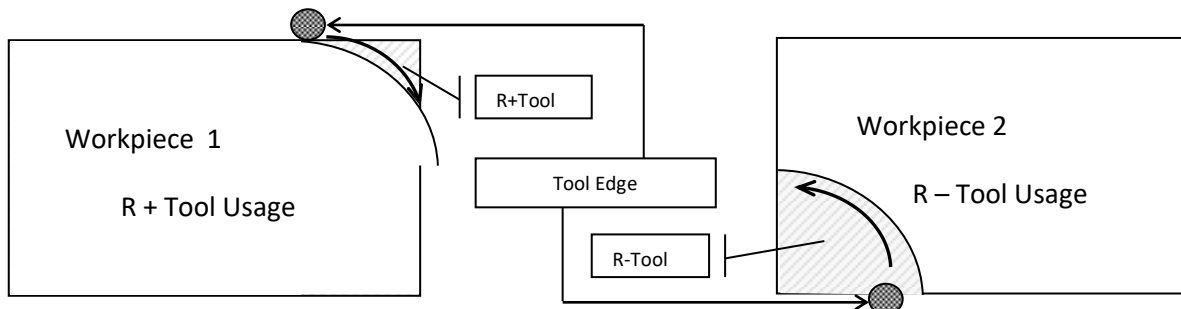

As on the work piece 1 convex would be given R+ Tool should be used. You can travel by button. After selection please press enter to save.

When there is writing “POINT 1” on the info screen, the 1. Point distance which will be drill on the axis will be determine. The table will be moved up to make zero the values and 1. Hole will be drilled. By button the 2. Point distance will be screened. The table will be moved up to make zero the values and 2. Hole will be drilled. For the next hole button is used and the sane operations are done up to finish all holes. Please press button to exit.

Example:

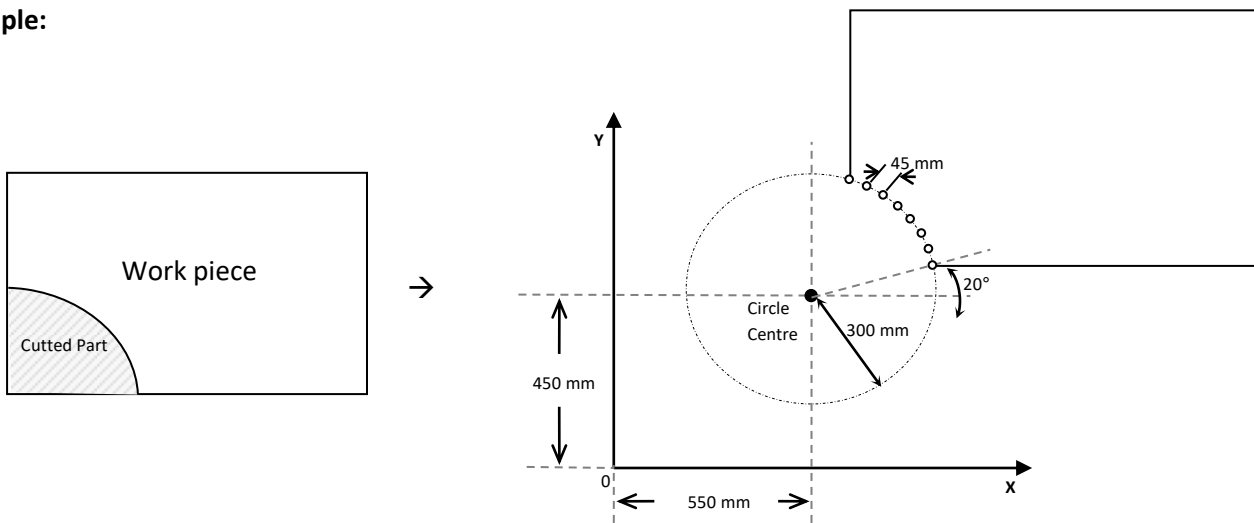

On XY plane , distance of circle centre to X axis is 550 mm, to Y axis is 450 mm, Radius is 300 mm, tool diameter 8 mm, max. Cutting distance 45 mm, reference angle 20°finished angle 80°and to applicate smooth radius function:

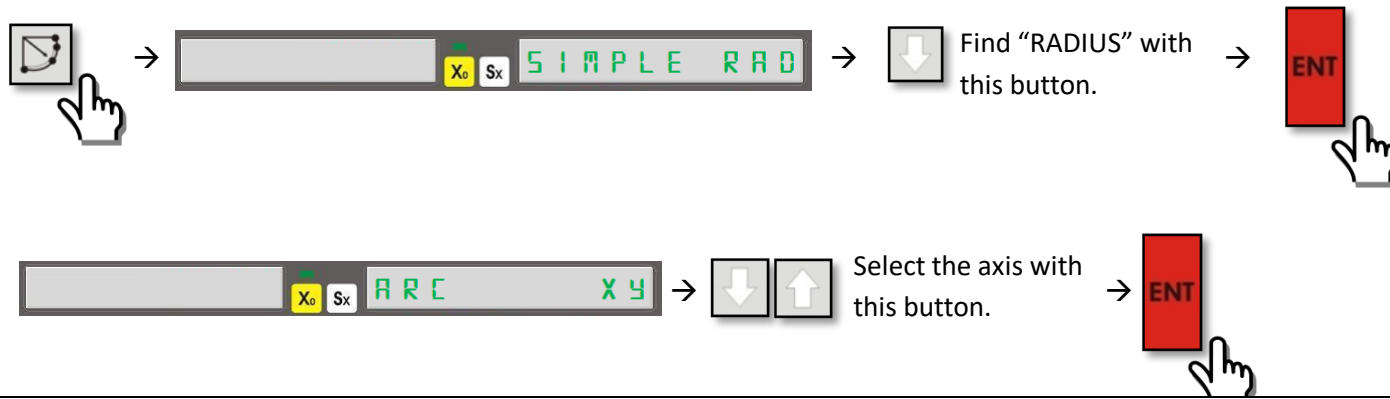

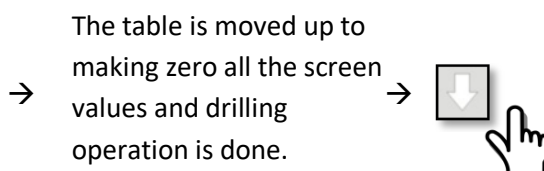
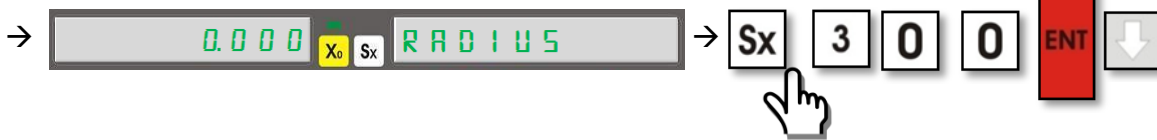
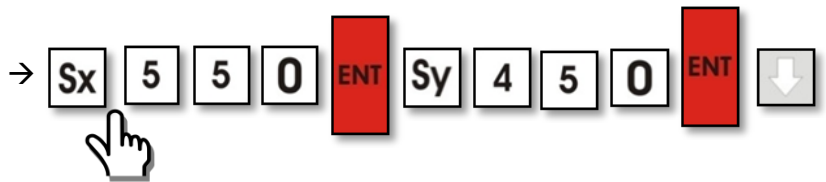

→ Point 2 values are screened. The table moved up to making zero all axis values and drilling operation is done. By ↓ button the following point is passed. For all points the same operations are done.

→ After all points, by ↺ button you can exit from the function.

5.11. Simple Radius (Milling)

This function is used to make accurate circle cutting on the work piece. The difference of the smooth function and simple function is, in simple function you don't give reference angle and finish angle, you only choice the needed one from 8 quarter circle. The present positions evaluates as circle centre.

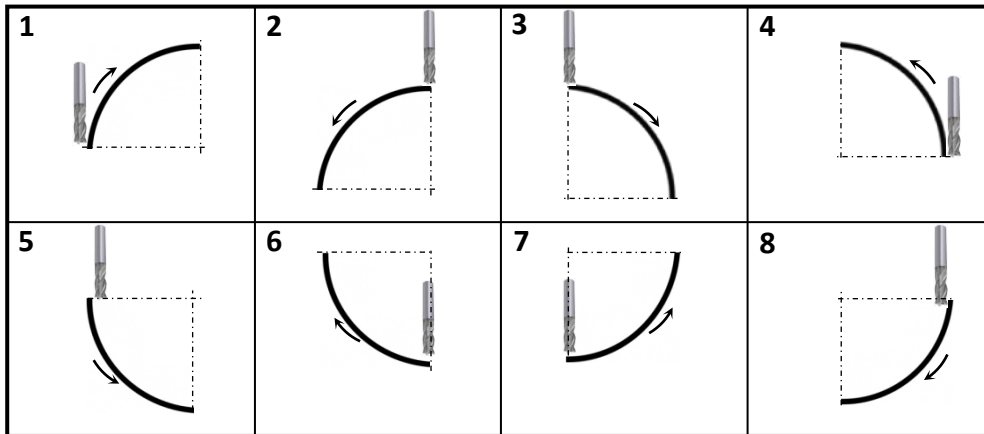

button is used to enter to the function. By button find the "Simple R." writing. Press enter and find the plane by buttons. Press enter to save. On the info screen after "TOOL PATH" writing, select one of the 8 tool ways. After writing the number as 1 to 8 press enter to save. Press "Sx" and enter the circle Radius. Press enter to save. Press button and press "Sx" again. Enter "Maximum cutting Distance and press enter. Press button for next step. Determine if the tool diameter must be add or subtract.

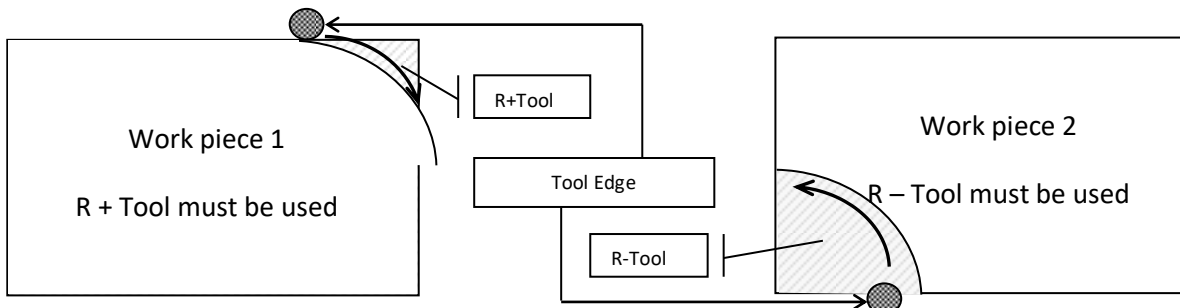

If convex radius will be done as work piece 1 "R+ Tool" must be selected. If the radius will be done concave as Work piece 2 "R-Tool" must be selected. You can travel by button . Press enter to save.

On info screen "POINT 1 " will be written and on the axes the distances of the point 1 will be seen. Up to make zero all axes the table is moved. And the Hole 1 is drilled. By button the point 2 distances will be seen. Up to make zero all axes the table is moved. And hole 2 is drilled. By button the next point is passed. Up to drill all holes the same operations will be repeat. Please press button axis.

Example: On XZ plane 50 mm diameter,
 6 mm tool diameter and 12 mm max. cutting distance
 simple radius as the picture direction;

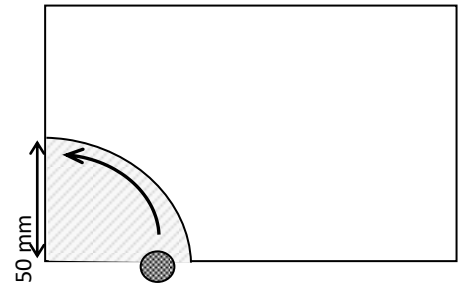

→ → → Find "Simple R" by this button → →

→ → Find XZ by this button → →

→ → → →

→ → → →

→ → → →

→ → → →

→ → Select R-TOOL (concave) →

→ → Move the table up to make zero all axis values on the screen and make drilling. → →

→ Point 2 values are seen. The table is moved up to zero the values. Drilling operation is done. The next point is passed by button. The same operations are repeated for all points.

→ After all points button is pressed to exit.

5.12. Linear Hole Patterns (Milling)

Linear Hole Patterns Function is used to drill holes on the work piece as grid which includes requested line and column number by user.

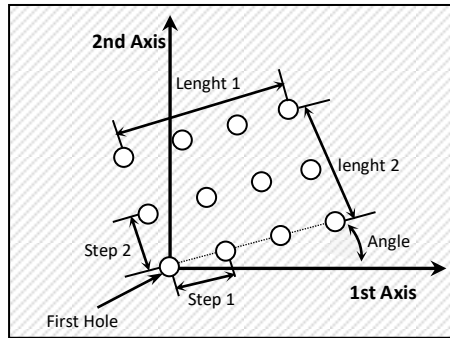

To make active linear hole patterns function the table is moved to first hole which will be drilled. button is pressed and "Cos / F1" button is pressed. On the info screen there will be writing "LIN.ARRAY" . Press enter to make active. By buttons the plane is selected. Press enter to save. Please select the "STEP" or "LENGTH" from two options by buttons. Select the distance and press enter to save. Press enter to pass the other step. Press Sx and enter the angle value. Press enter to save. Press button and press Sx again and enter the column .numbers. Press enter to save. Press Sy to enter the line numbers. Press enter to save. Press button. You will see the distance for the first hole. It will be "0". After drilling press button you will see the distance for the 2. Hole. Move the table up to make zero the values and make drilling. Press button to pass following holes.and repeat the same operations. Press button to exit.

Example: XY plane ,

Distance between column: 50mm

Line Distance: 40mm

Angle: 20°

Column quantity: 3

Line quantity: 2

To use linear hole patterns function by the givens;

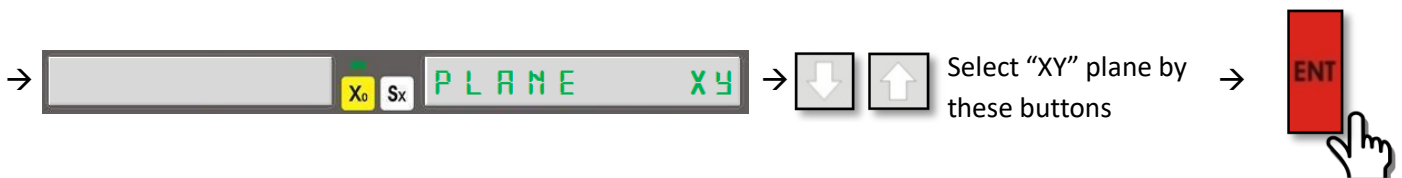
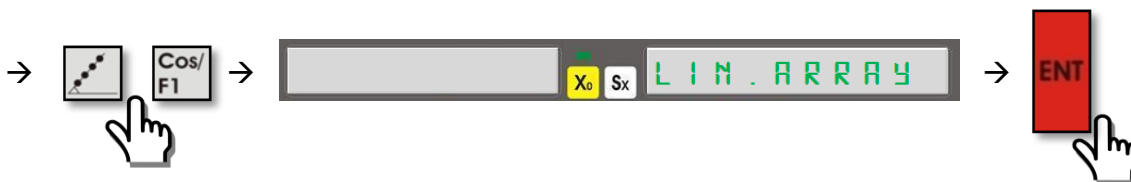
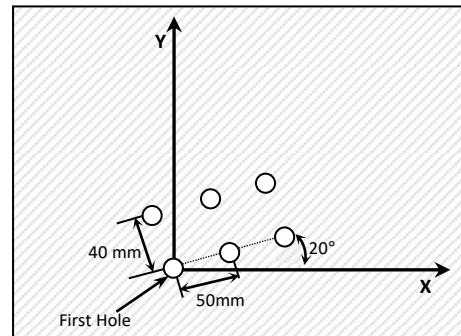

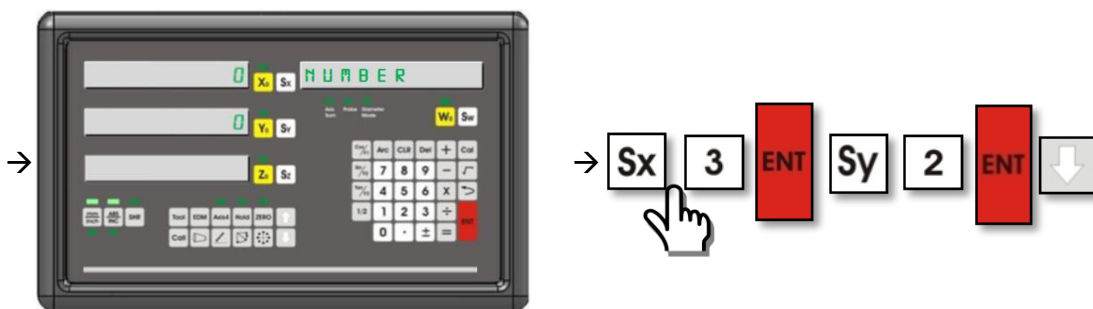
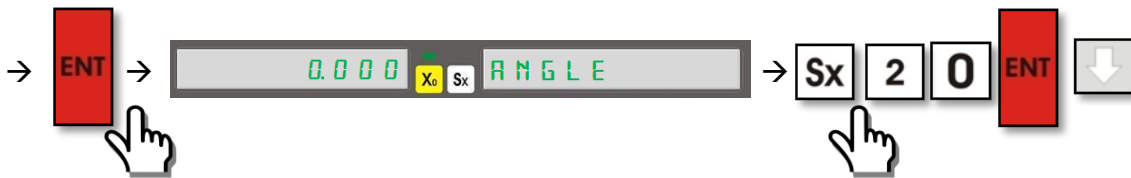
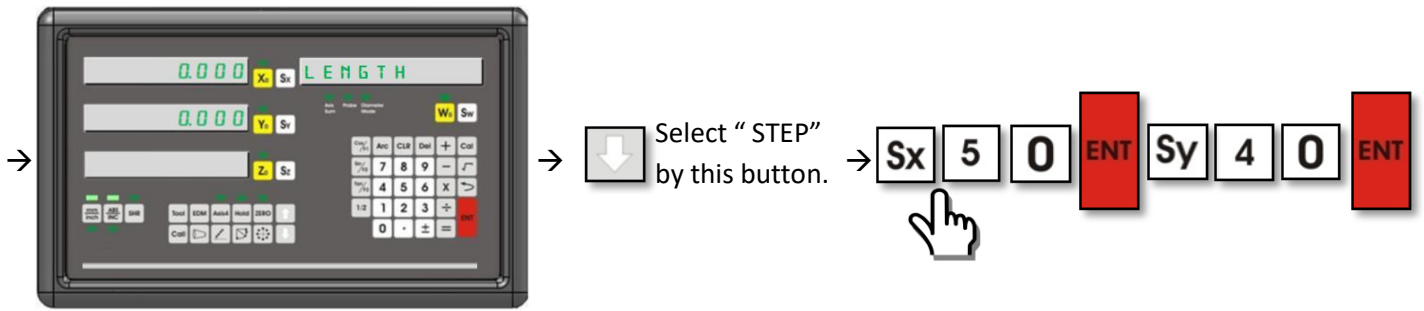

→ By  button the coordinates are screened. All operations repeat for all points.

→ After drilling of all points you can exit by  button.

5.13. Frame Hole Patterns (Milling)

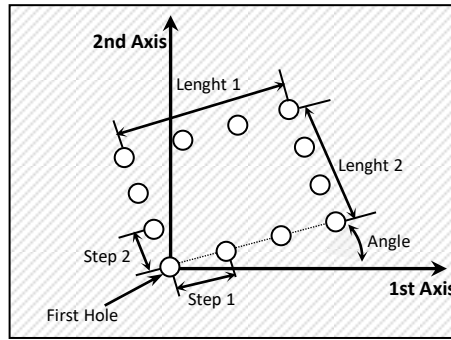

Frame hole patterns function is used for to make a frame which created by the holes on the determined plane of the work piece. The edge hole numbers must be determine by the user.



To active the function move the tablet o the first hole point. Press button and press “Sin / F2” button. You will see “FRAME” writing on the screen. Press enter to open the function. Select the plane by the buttons. And press enter button. The user has 2 options here . He can choice the distance between 2 holes as “STEP” or choice the distance between the first hole and last hole as “length”. Use buttons for this choice. Press axis selection buttonc and enter the lenght / step value and press enter to save. Press enter for next step. Press Sx button to enter the angle value. Press enter value. Press button and press Sx button again to enter the clounm number. Press enter to save. Press Sy button to enter the line number. Enter the value and press enter to save. Press button and see the distance value on the screen . For the first hole the value will be “0” . After drilling press button and see the djsitance for the 2. Hole. Move the table to up to make zero the value anddrill the 2. Hole. By Button the next step is passed. These operations must be repeat for all holes and press button to exit.

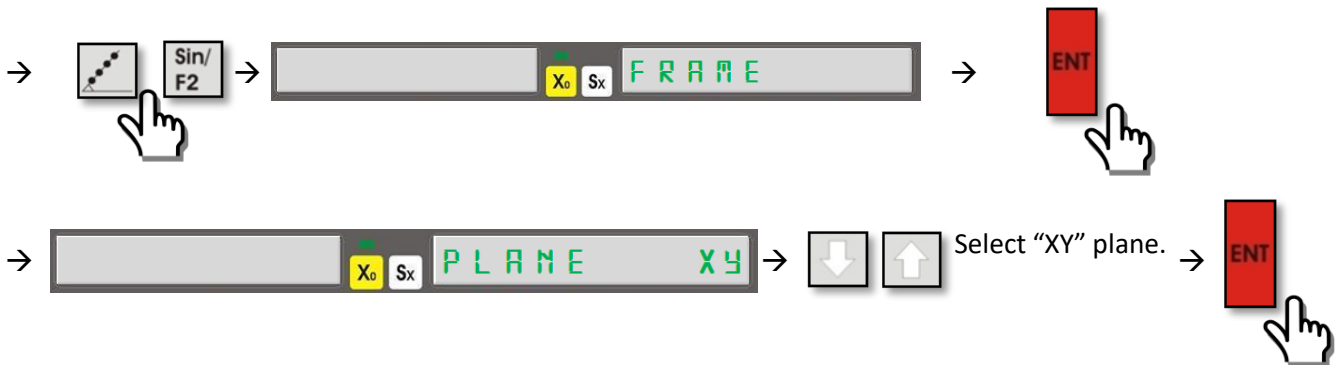
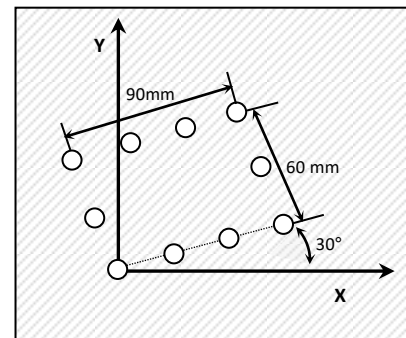

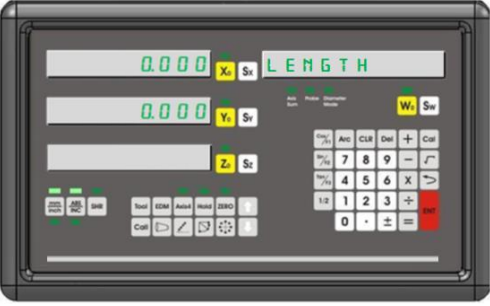
Example: On XY Plane,
 Column Length: 60mm
 Line Length: 90mm
 Angle: 30°v
 Column Number:4
 Line Number: 3
 To use the function with the above data;

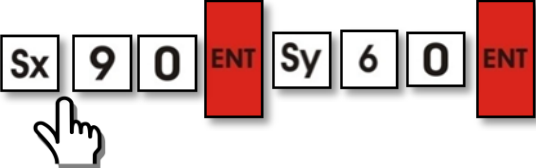

→  →  Select "LENGTH" → 

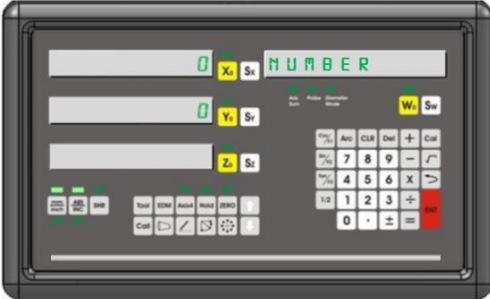
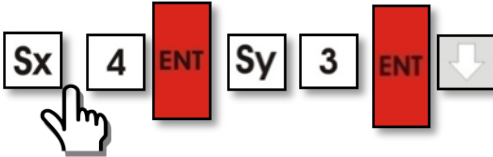
→  →  → 

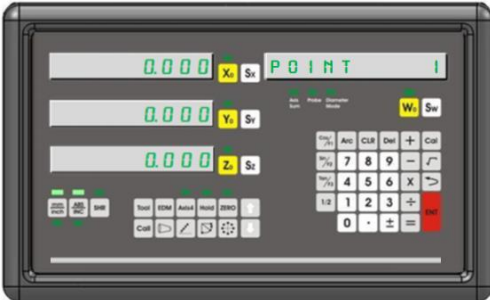
→  → 

→  → It is the first hole so the values are "0". → 

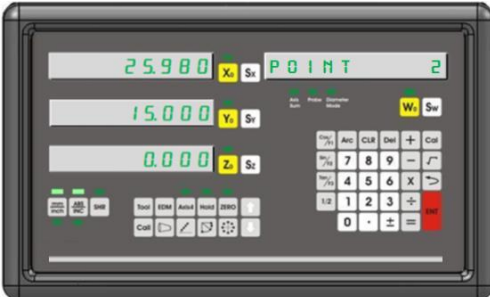
→  → Move the table up to make "0" all values

→  Pass to next hole . Repeat the operations for all holes.

→ Press  button to exit after all holes are drilled.

5.14. Rectangular Pocket (Milling)

When a rectangular hole is need on the work piece this function is used. It is good for a quality rectangular hole and a better working time. The reference point is centre of the rectangular hole.

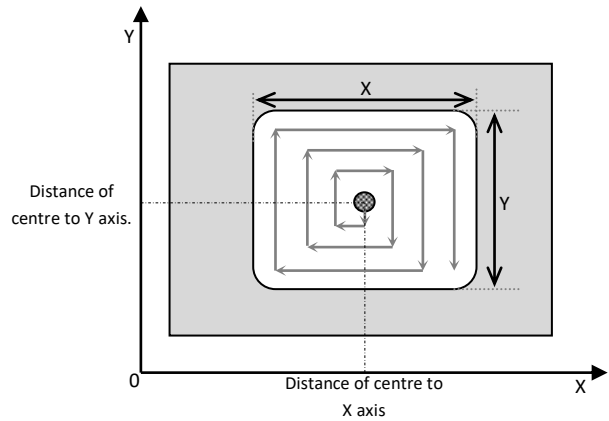
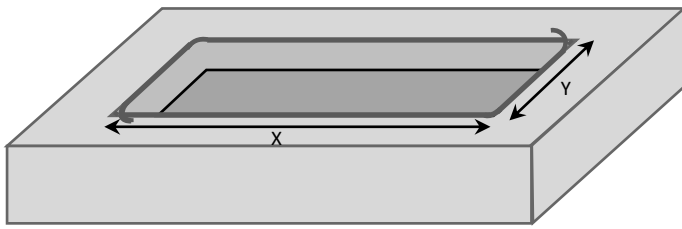

To use the function press “Cos/F1” button. After pressing Sx button enter the tool diameter. Press enter to save. If the tool is with Radius press “1” button to see “L-1” on the screen. If there is not Radius press “0” to see “L-0” on the screen. Press button to pass next step. Press Sx button and enter the distance of the X axis to the reference point. Press enter to save. Press Sy and enter the distance of reference point to Y axis. Press enter to save. Press button and Sx button and enter the length of X axis. Press enter to save. Press Sy button and enter the length of Y axis and press enter to save. Press button to screen the moving distances. The table is moved up to making zero the values. Press button and repeat the same operations for the other points. Press button to exit.

Example: Tool diameter: 8mm, no radius
 Start point distance to X axis: 110 mm
 Start point distance to Y axis: 90 mm
 Rectangular Pocket X axis dimension: 100mm
 Rectangular Pocket Y axis dimension: 80mm
 Finish Depth: 3mm

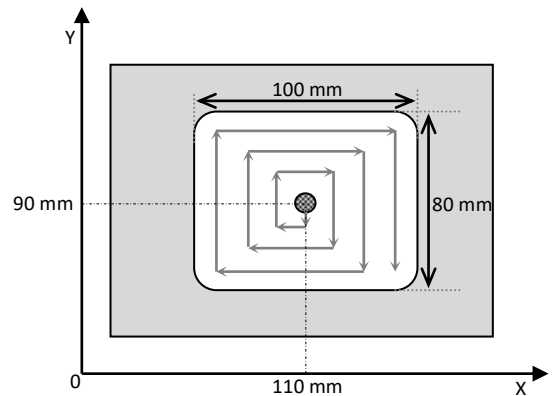

To use rectangular pocket function with these data;

→ → → → → See L-0 by pressing “0” button because no radius on insert tools.

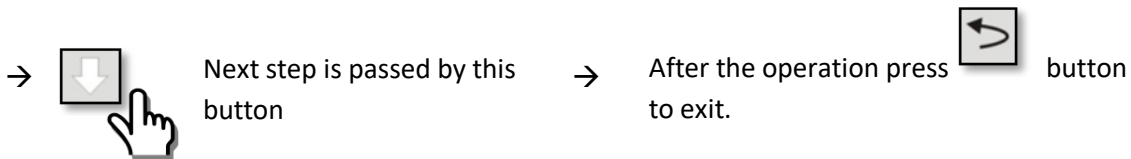
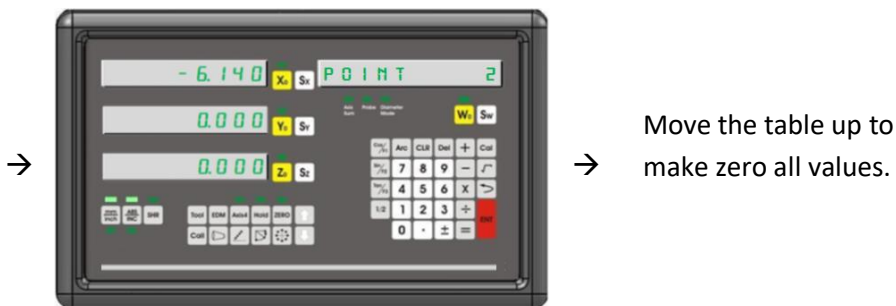
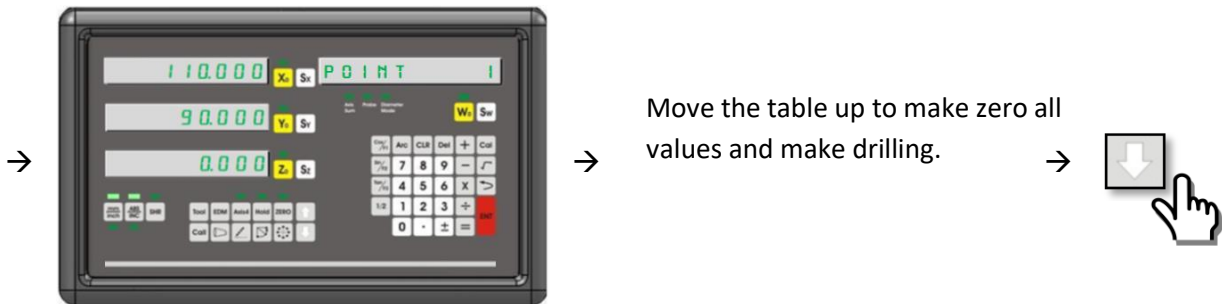
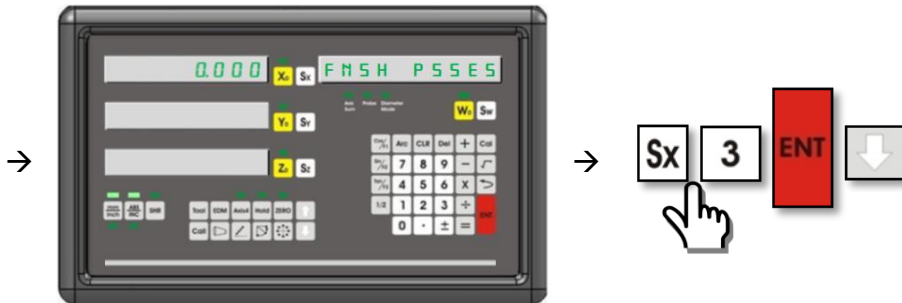
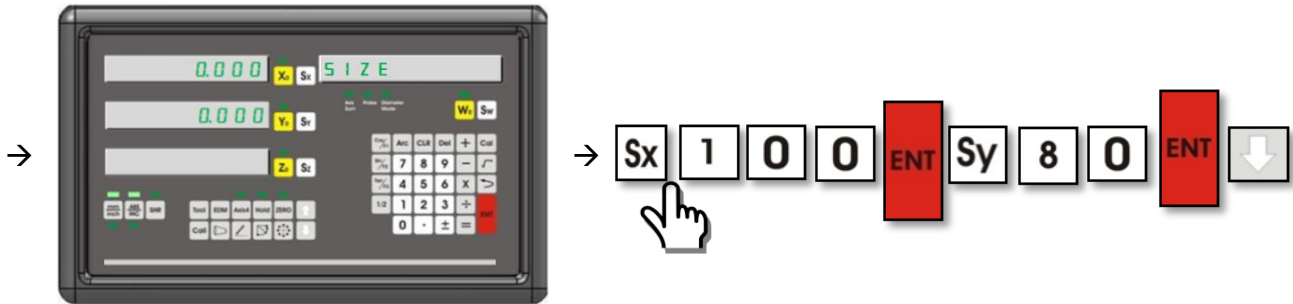
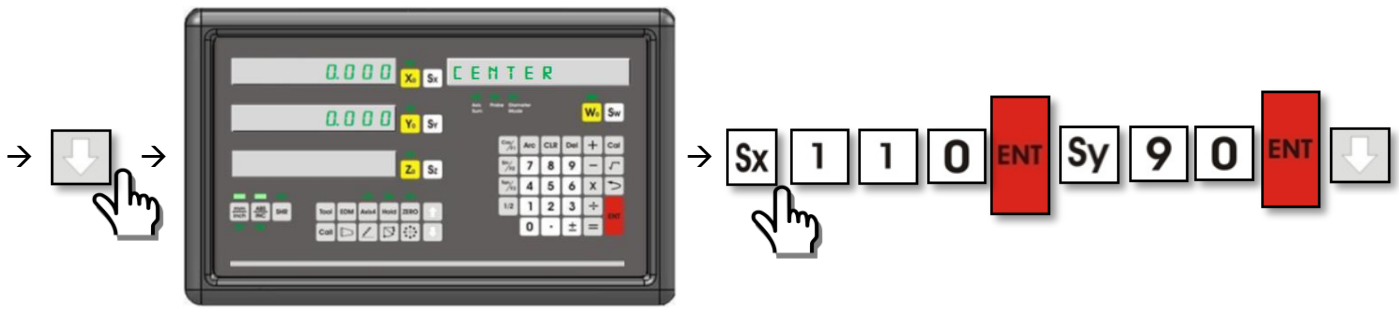

5.15. Work Piece Angle Measuring (Milling)

By angle measuring function it is possible to measure the work piece angle.

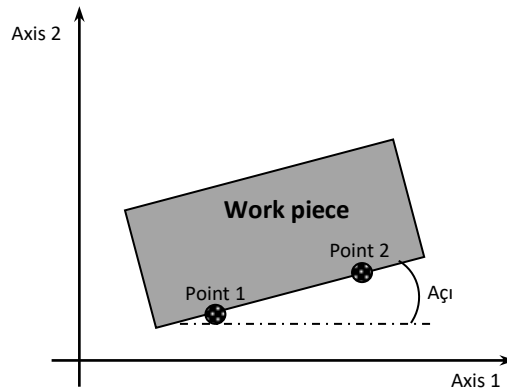

For measuring the tool edge is moved to "Point 1 " position. Then press button to enter the function. By buttons select the axes which will be measure and press enter to save. When the tool edge moved to Point 2 on the upper line there is written the angle. On the second line degree.minute.second values are screened by button you can axis.

Example:

To find the angle of the work piece as the left side;

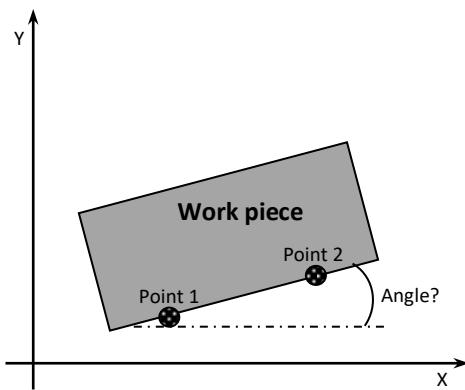

Move the tool edge to point 1 .



Select "XY" plane by these buttons .

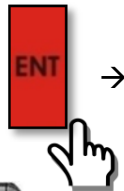

Move the tool edge to Point 2

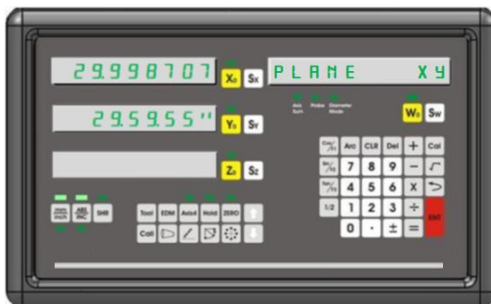

See the angle as 29.998°.

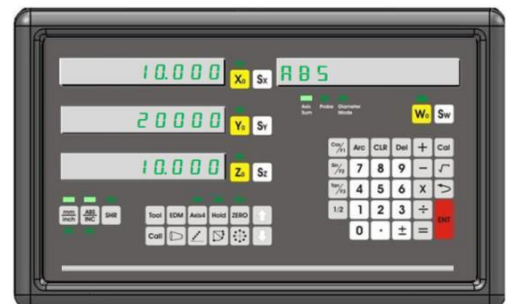

5.16. Touch Probe (Milling, Boring)

To MIKRONEL 500 series digital coordinate readout displays touch probe can be provided. When the contact probe contacts to metal work piece the probe leds sign and probe menu is entered. By touch probe it is possible to make axis zero / setting half value of the axis value, find center, measurement functions. Touch probe function can be opened by pressing 10 times to x button on calculator and it is closed as the same way.

5.16.1. Zero the Axis / Setting Half Value of the Display Value

When the contact probe is contacted with the work piece find the "ZERO" selection by  buttons. Press axis selection button. When you cut the contact it zeros the axis and exit from the function automatically. Setting half value of the display value, when you are on "ZERO" menu, select the axis and press "1/2" button.

Example: For setting half value of the Y axis value;

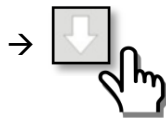
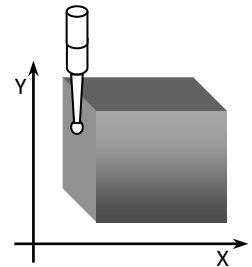
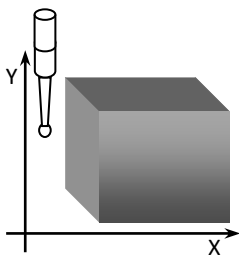

Find
"ZERO"

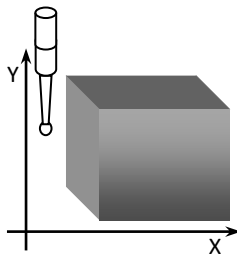
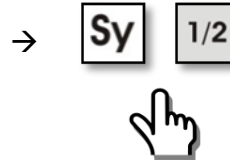

5.16.2. Find Center

To find the work piece centre by contact probe, probe is contacted to first reference point of work piece on X axis and when the menu is opened find the "CENTRE FND" option by  buttons and press enter to open the function. The probe uncontact to work piece and it is contacted to 2. Reference point on X axis and probe uncontact. The first reference point of Y axis is contacted and uncontacted. Then the probe is contacted to 2. reference point and uncontact. After seeing "OK" writing on the screen press enter to see the distance to work piece centre.

Example: To find the centre of the work piece by probe as below;

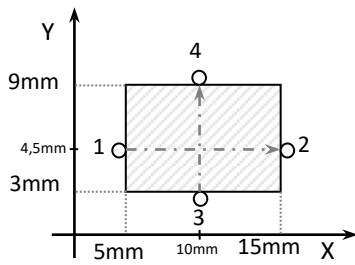

Contact the probe to reference point 1 →

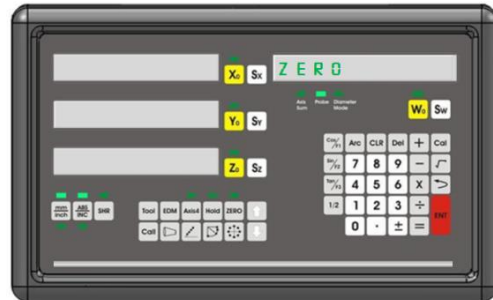

Find "CENTER FND" →

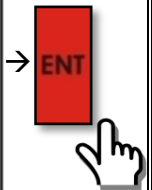

Contact the probe to reference point 2 →

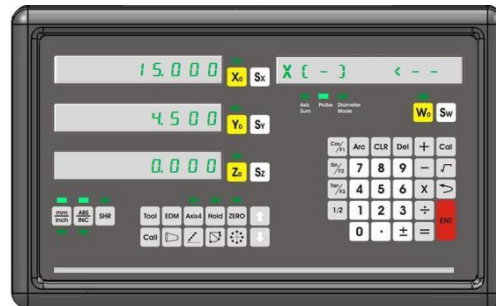

Contact the probe to reference point 3. →

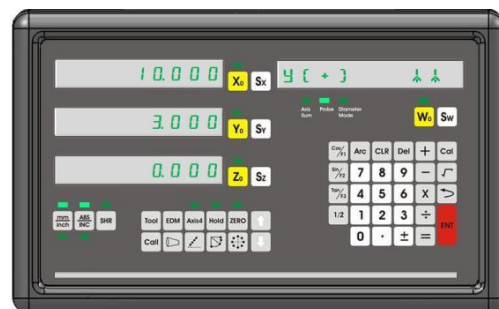

Contact the probe to reference point 4. →

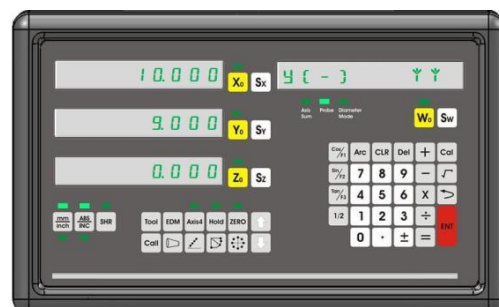

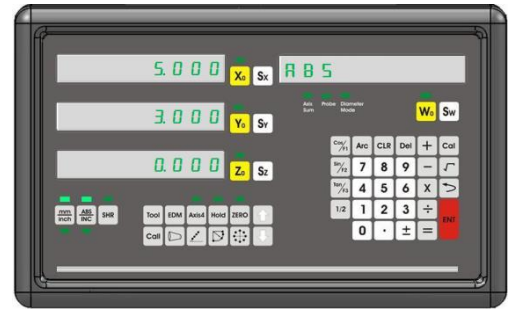
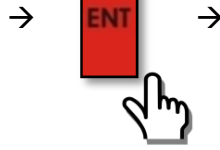
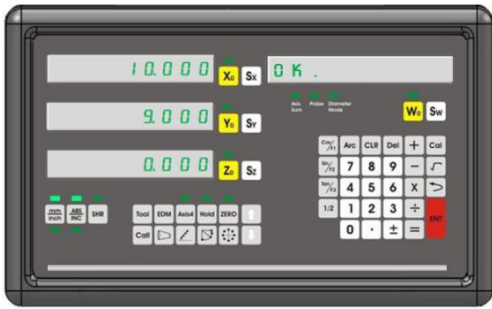



When the work pieces are moved up to make zero all axes you will find the work piece centre.

5.16.3.Measurement

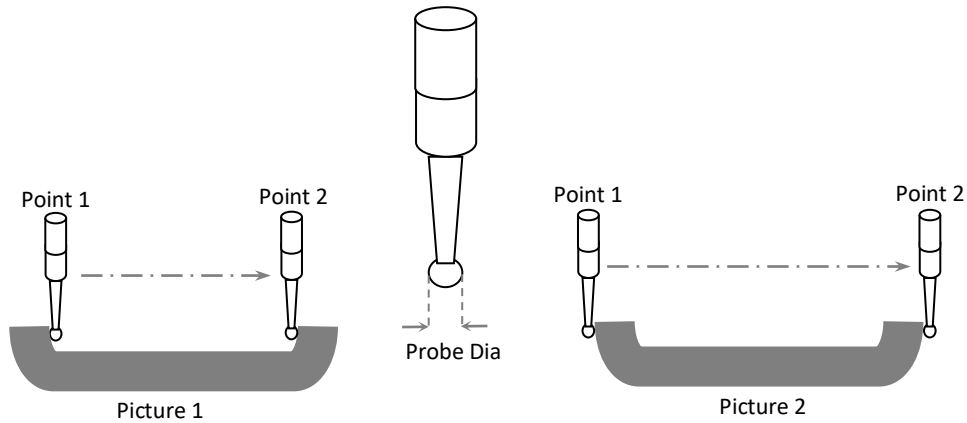
To measure with contact probe when the probe is contacted to the work piece on the opened menu find "MEASURE" section by  buttons and press enter to select. Probe must be contacted to Point 1.



On the opened function menu, the measure effect of probe is adjusted. If the measure of the work piece will be taken as in the Picture 1 press "1" button and see "+DIAMETER" writing on the screen. If the measure of the work piece will be taken as Picture 2 press "0" button and see "-DIAMETER" writing on the screen. Press "Sx" button and enter probe diameter and press enter to save. Press  button to see "POINT 1" writing . Press button of the axis selection. When you uncontact the probe device save Point 1. When you contact Point 2 the length will be deal to user.

Example:

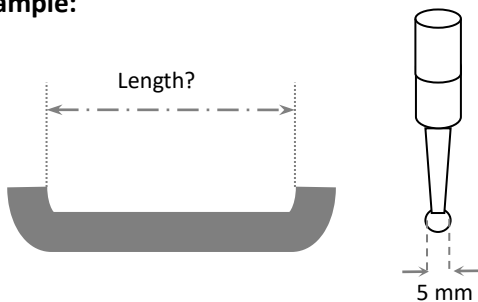

As the left side picture to find inner dimensions of Y axis

(First contact Position;

X: 26.110 Y: 61.200 Z: 0.000)

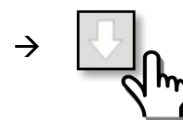
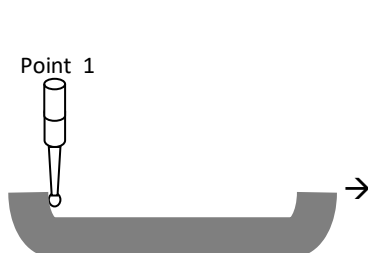

Find "MEASURE"

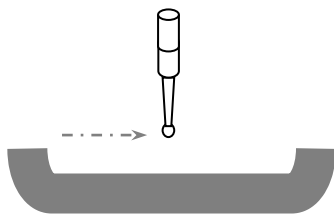
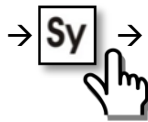
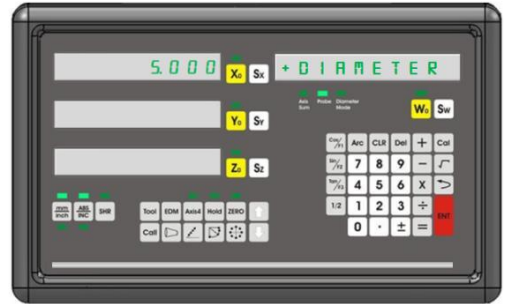
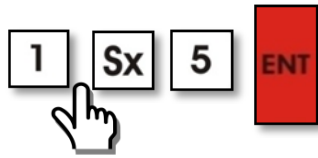
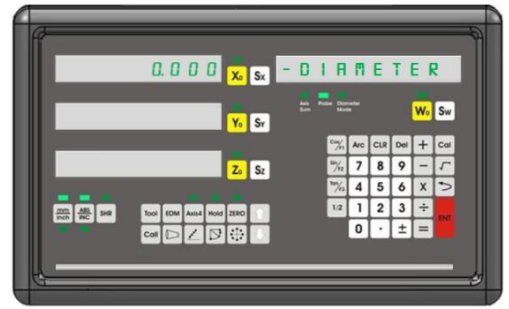
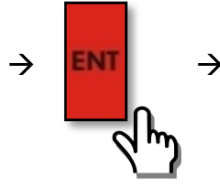
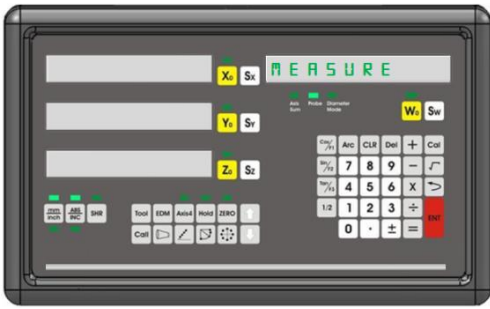

The length is calculated as 75 mm. Please press  button to exit.

5.17. Tool Diameter Compensation (Milling)

Tool diameter compensation is used to prevent the machining errors because of the tool diameter effects.

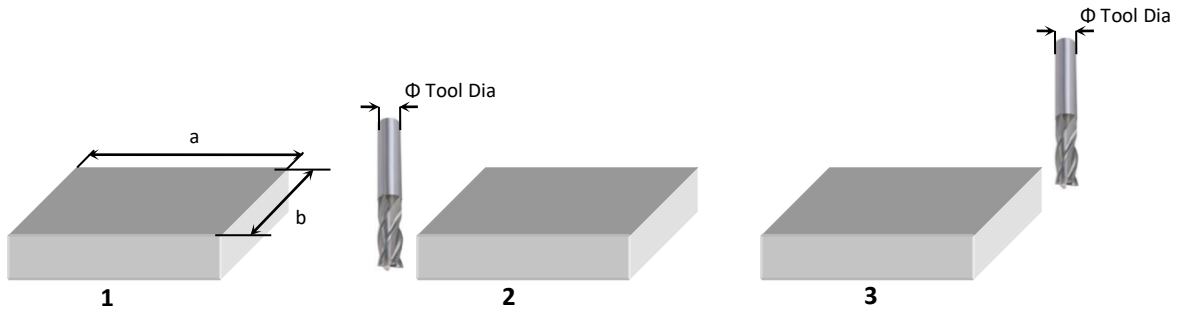

As example the 1st Work piece wants to be machined. If you consider only a and b dimensions, because of the tool effect the work piece will be machined wrongly. It is also important which work piece will be machined on which side.

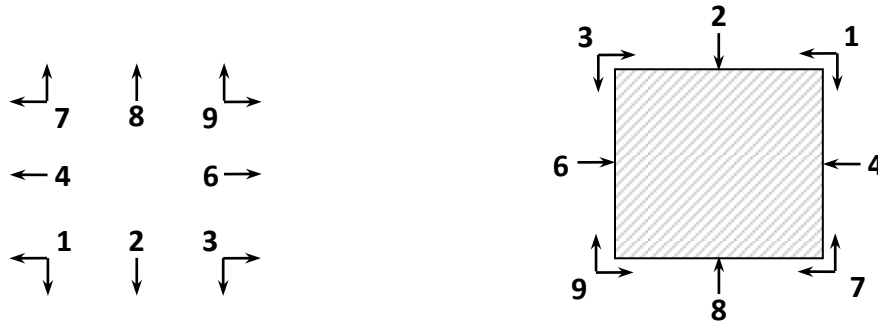

For Tool Diameter Compensation function move the tool edge to the start point which the machining will be started. And Tan / F3 button is pressed. On work piece the machining side must be selected by numeric buttons. By button the next stepped is passed. Press Sx button to enter tool diameter. The table is moved up to seen the values of the real dimensions of the work piece.

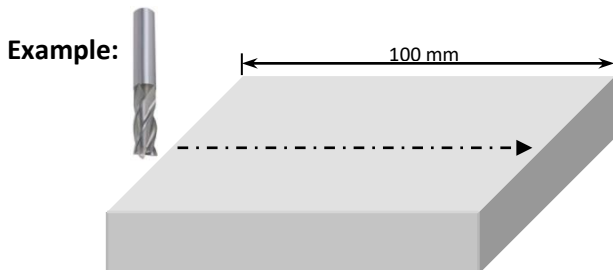

Tool Diameter : 8mm

To machine the workpiece as the left picture;

Move the tool to start point;

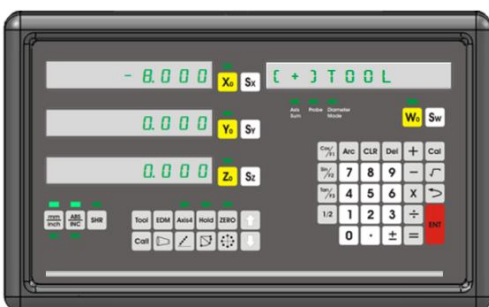

→ The work piece will be machined up to the X axis values are 100.000.

5.18. Tool Storeroom (Lathe)

While machining the different work piece or different surfaces of the work piece, the different machine tools may be needed. So you will need to change the machine tools. ADR10 digital coordinate readout has 1000 pcs tool memories. By this way you don't need to get zero point for each tool changing.

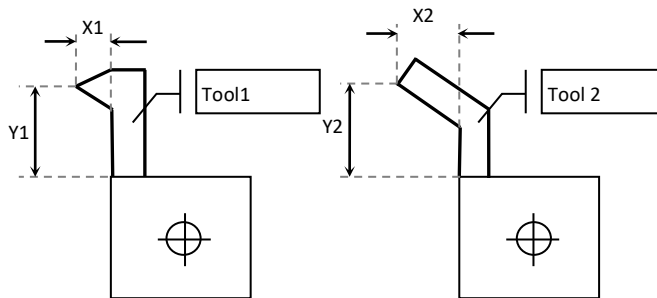

The tool must be open to use this function. To open the tool $\boxed{\pm}$ button must be pressed 10 times to open the tool. The registration of the tools can be made by automatically or manual. For automatic registration please press $\boxed{\curvearrowright}$ button and "Tool" button. The memory number must be set. On the zero point of X axis "Sx" button is pressed..On the Y axis "Sy" button is pressed accordingly.

For manual setting of tool memory "Tool" button is pressed and "Zero" button is pressed accordingly. Then the memory number is set and "enter". Sx button is pressed and X axis length is entered. Sy button is pressed and Y axis length is entered button is pressed. You can exit by $\boxed{\curvearrowright}$ button. To make easier generally "0" is used for memory number. For reference number of the tool dimensions "0" can be used for easy.

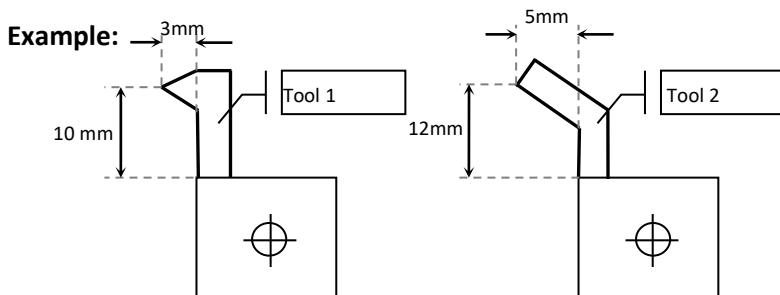

To memory; 2 different tool and to set tool1 as reference and tool2 as selection as left drawing

Tool Memory Setting First Way (Automatically):



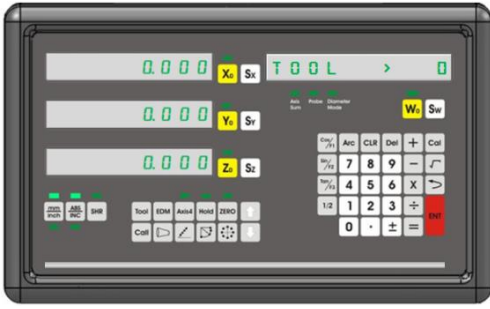

→ Determine X axis as reference point. →

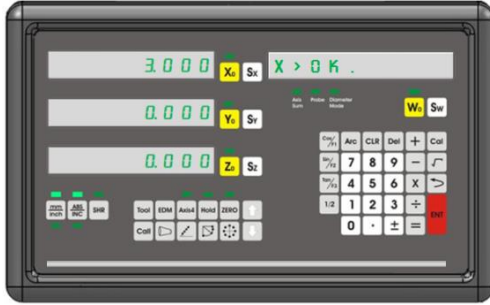

→ Move Y axis to zero point. →

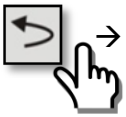
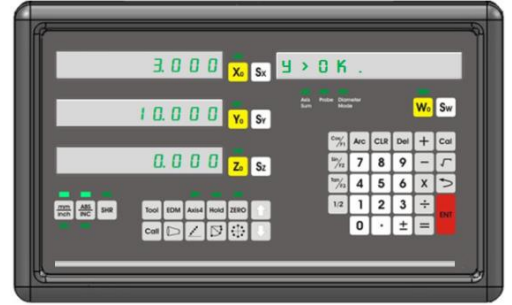

Install 2. tool

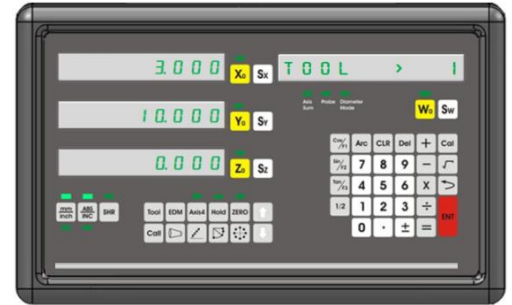
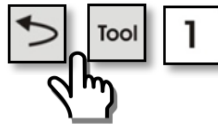

Move X axis to zero point.

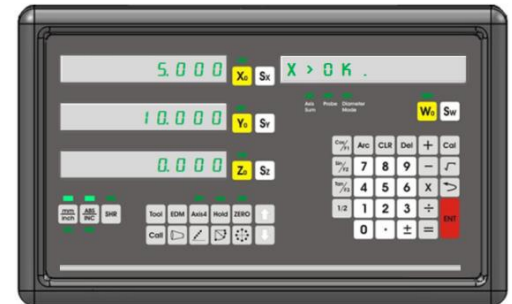

Move Y axis to zero point.



Tool Memory Setting Second Way (Manual): Move Y axis to zero point.

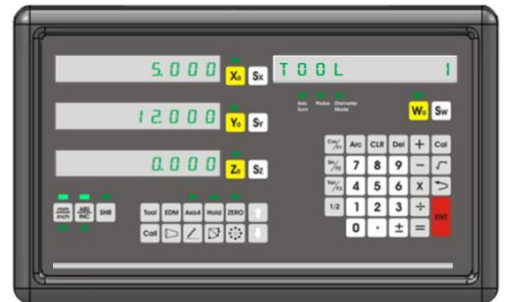
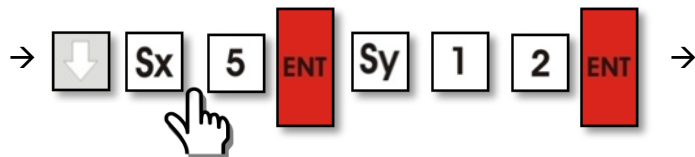
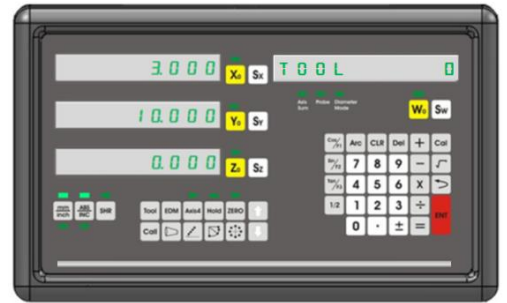
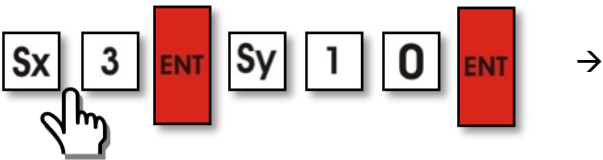

Selection of used tool and reference tool:

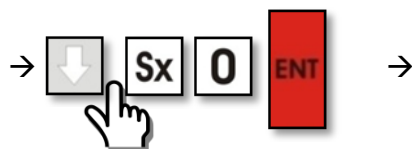

5.19. Taper Angle Measurement (Lathe)

This function is designed for Lathe Machines to measure the Taper Object Hill Angle.

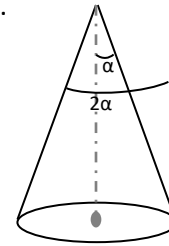
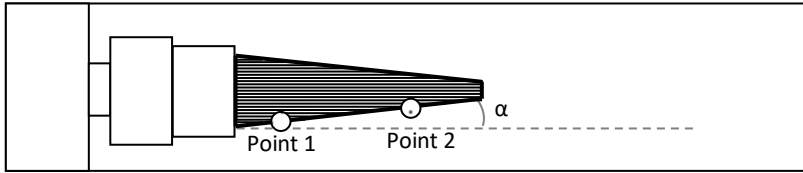

To taper object angle measure the tool edge moved to reference point and button is pressed. Then move the tool edge to 2. Reference point and press enter. On X axis 2α angle and on Y axis α angle is seen.

Example: To measure the angle of taper work piece which connected to the lathe;

Tool moves to 1. reference point.

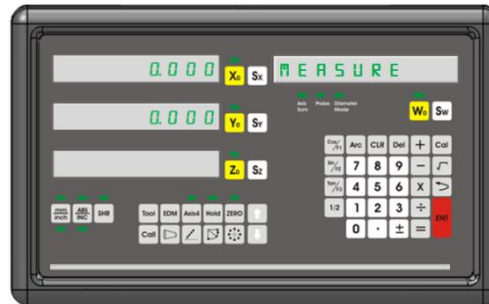

Tool moves to 2. reference point.

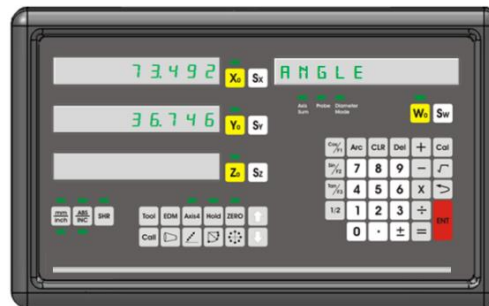
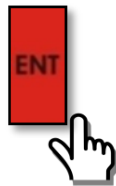

$\alpha = 36,746^\circ$

$2\alpha = 73,492^\circ$

5.20. Digital Filter (Vibration Filter)

In some applications because of vibration or scale the values of the display can be always change. For example in grinding application because of the grinding machine vibration the values of the DRO display can be always change . It disturbs the user. So we have added vibration filter function to the device. By this function renewing ratio of the display is delayed and it makes easy usage for user. This delay never caused the position errors. The values are not error, they are always correct position values. To change the display renewing ratio “EDM” button is pressed. Then “Sx” button is pressed and the renew time is set and “enter” is pressed to save the value. If the screen type is selected as “erosion” type, please use “tool” button instead of “EDM” button to enter the function. The renew time must be between 10ms and 500 ms. The vibration decreases by the value. To exit please press button.

Example: To make 100 ms the renew time of the screen;

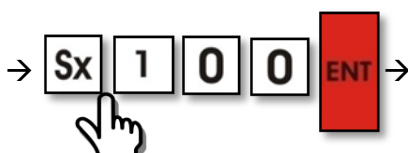

5.21. Inclined Z Axis Machining (Milling)

This function is used to make inclined on the Z axis. This function is made on XZ or YZ plane.

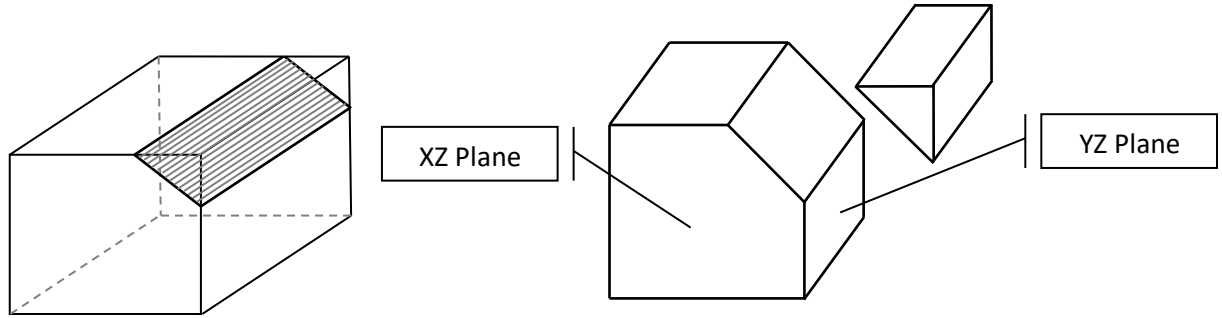

The tool edge is moved to start point and press “Sin / F2” button and by buttons and the düzlem is selected. Press enter to save. Press Sx and enter angle (α) and press enter to save. Press button and press Sx button and enter Z axis step distance (ΔZ) and press enter. If the step distance is upper side save it positive or if it is down side save it as negative. When you press button you will see the first point coordinates on the screen. If you select “YZ düzlem the coordinates of X and Z axis will be changed or if you select XZ düzlem Y and Z axis coordinates will be changed. Move the table up to make zero the axis values. Press button for following steps.

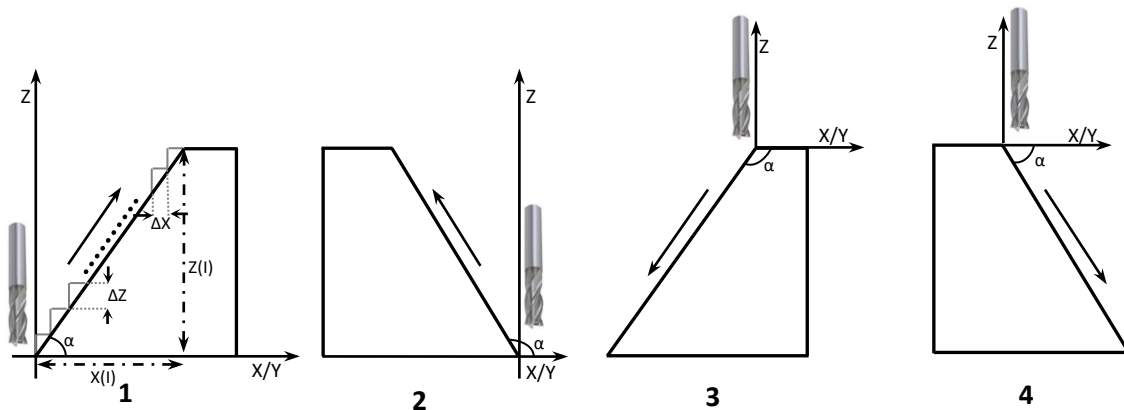

$$X(I) = \frac{\Delta Z}{\text{tg}\alpha}$$

$$Z(I) = \Delta Z \times I$$

$$\Delta X = \frac{\Delta Z}{\text{tg}\alpha}$$

I: Step Number

ΔX : X Axis Step Distance

ΔZ : Z Axis Step Distance

* Inclined Z axis machining function is used as 4 different way. Before using the function enter the “ α ” value as angle value.

Example:

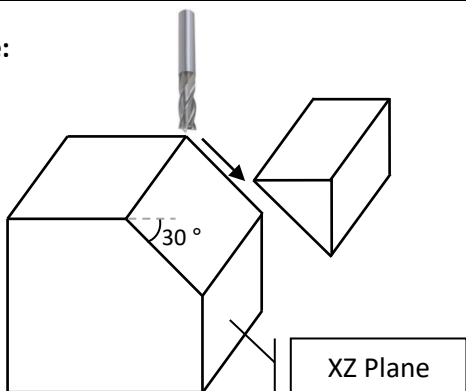

To machine the workpiece as lecf Picture , on XZ plane, 30° angle and 0,1 mm Z axis. 0,1mm Z axis steps;

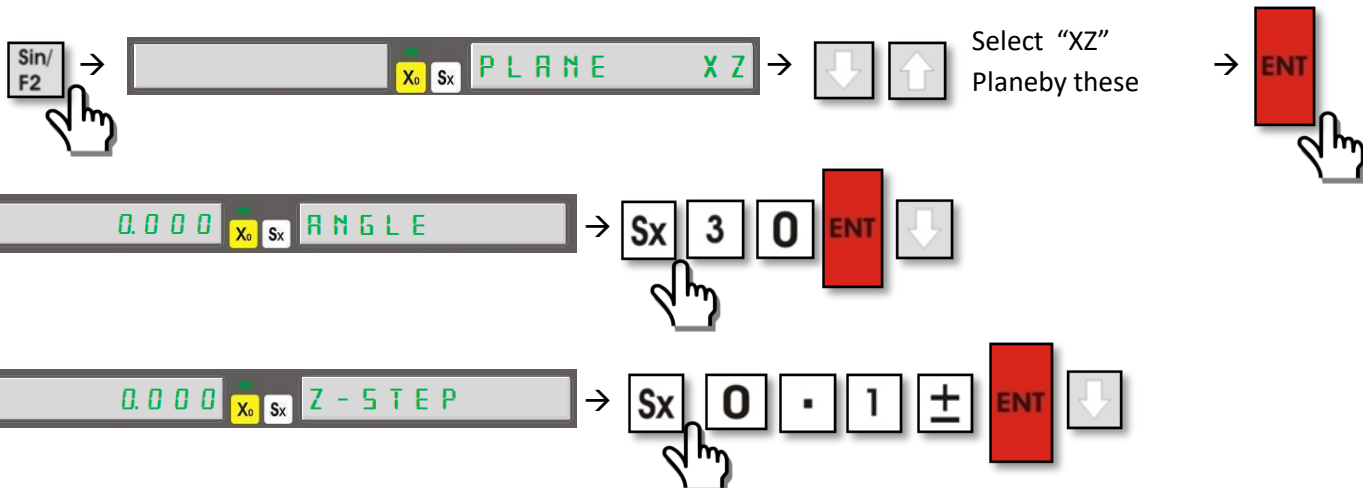

→ The workpiece is machined up to axis values are zero. By [↓] button the next coordinate is screened. Up to machine whole part these operations are repeated. Press [↶] button to exit.

5.22. EDM Depth Control Function (Erosion)

This function is used for depth control on the erosion machines the work piece which will be machined Z axis. To enter of the offset values is also possible to compensation of the electrode errors. Also two different mode can be adjusted. When “MODE 0” is adjusted relay will be on and it continues up to requested depth. Also the device will warn you when the requested depth is received.

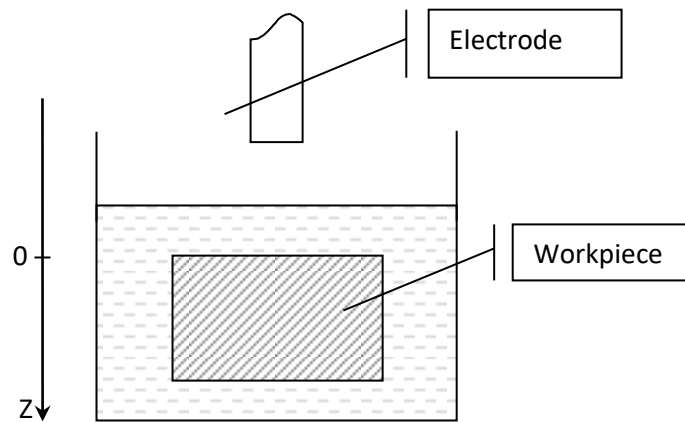

When the electrode contact with the work piece the axis values will be zero. Press EDM button to enter the function. On info screen you will see “DEPTH” writing . Press Sx and enter the depth value. Press enter to save. By button you will see “Offset” writing on the info screen. Press Sx and enter the error value which would be occur by electrode. Press enter to save. This value will be added to depth distance. Press button again and press 1 or 0 button to select operation mode and press enter to save. When you select Mode 0 the relays will be on up to requested depth. If you select Mode 1 relays will start with the normal position and it will be on when the requested depth is received. After mode selection please press enter to save. And press button to start.

While operation the “Z” led will be signed. On X axis the value which will be continue without offset is seen and on Y axis you will see the max depth value. On Z axis you will see the present value.

Description	Pin Number	Function
P1	1	Standard Open Pin
C1	2	Common Edge
P2	3	Standard Closed Pin
C2	4	Screen

Örn:

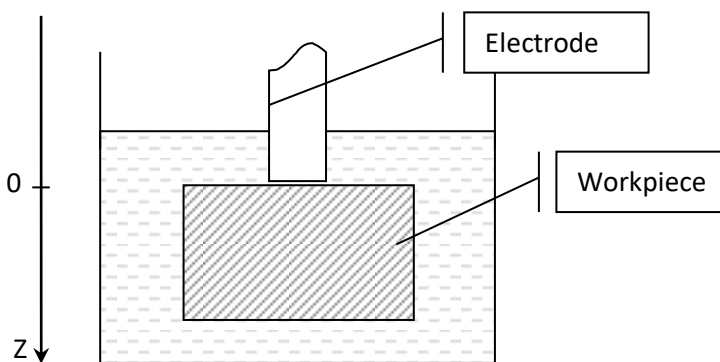

The workpiece wants to be machined up to 50 mm depth as the left side picture. Because of the electrode abrasion the dimension decrease 3 mm. The relay wants to be changed the position when the requested depth is received. To use this EDM function to control the depth;

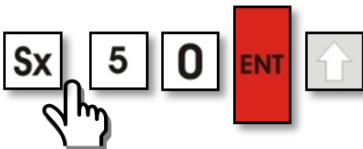
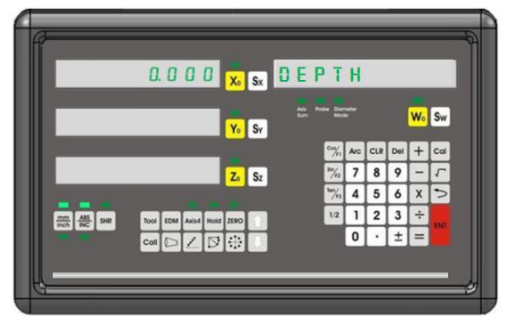
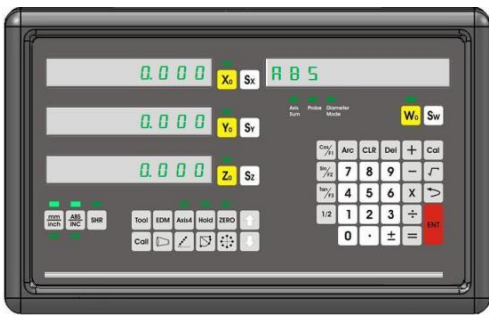

It shows 3 mm deficient so 3mm is added. If it shows 3 mm over the offset value will be enter -3.

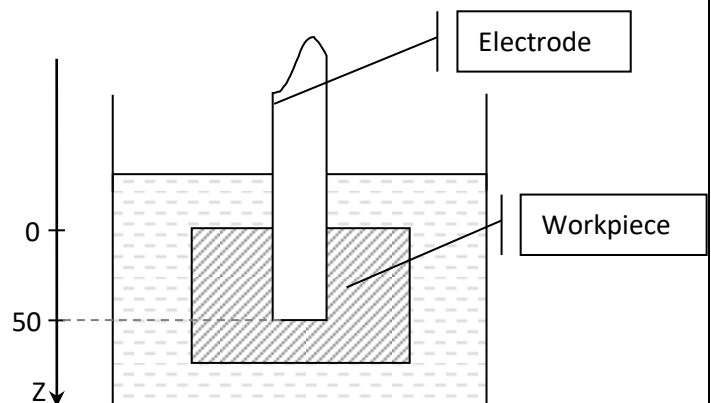
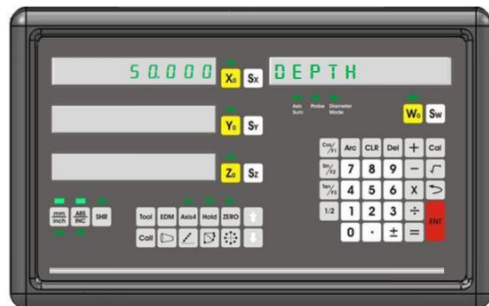
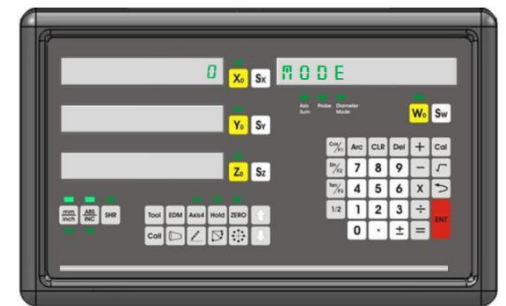
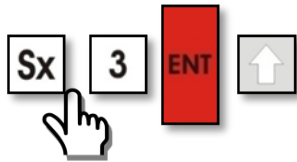

When 50 mm + 3 mm (Offset) depth value is received the relay changes its position and digital readout warns the user both by written and soundy. To axis press EDM button or enter or button. If the Mode 0 would be used the function would be exised automatically.

5.23. HOLD Function

You can freeze the values open the requested axis. After freezing the axis value if you move the tablet he axis value can continue with the new position of the table. Or it can continue with the frozen values.

To activate the function select the axis which will be frozen and press "HOLD" button. Press again "HOLD" button and you can move the table. The axis will be continued with the last position value. If you exit by  button if the table position is changed the axis value continue with the new value.

Example: Hold function for Y axis;

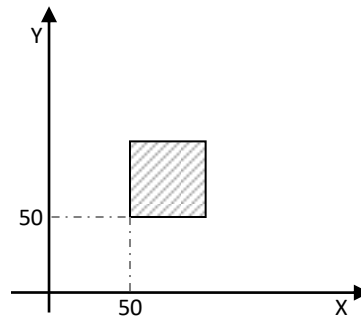
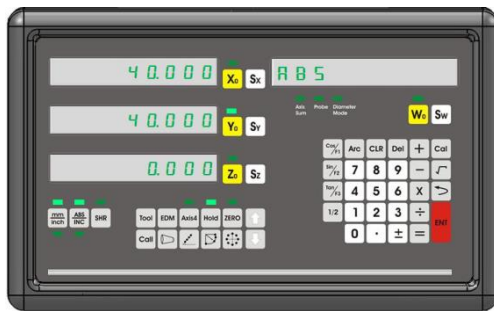
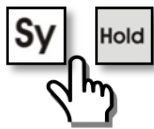
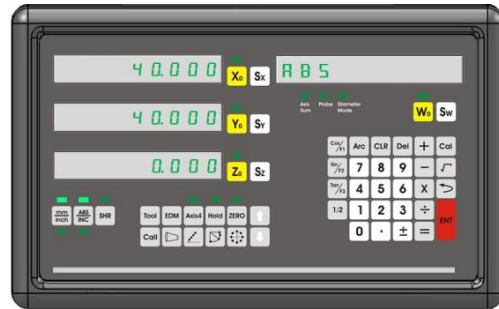
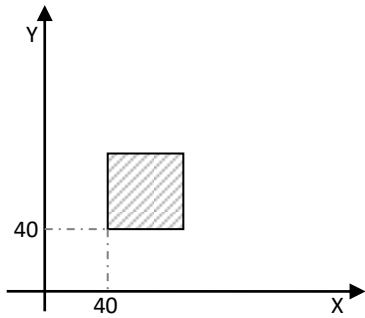

When the workpiece position is changed;

X:50 Y:50

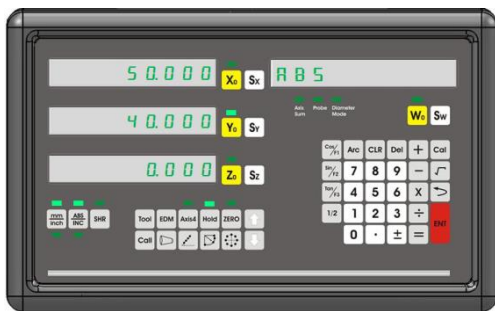

2 ways for axis

Way 1:

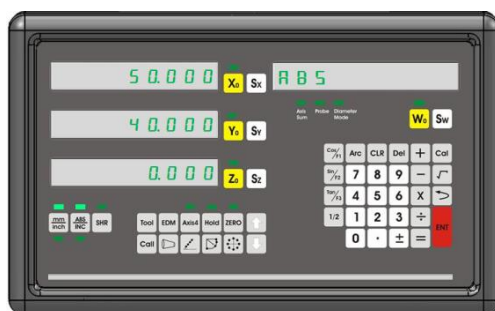

Way 2:

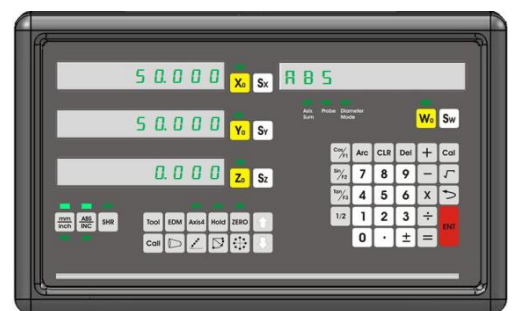

5.24. Data Transfer by RS – 232 Port

There is RS – 232 port on MIKRONEL 500 digital readout. By this way the coordinate data can be follow by computer. It transfers the same coordinate informations if the DRO has how many coordinates. RS-232 port, can transfer the values up to 15 meter far. (Baud rate: 57.600, Parity None, Stop Bit:1)

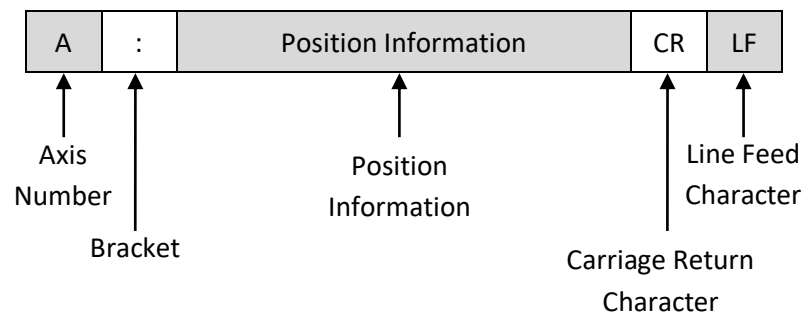

For X axis , axis number is 0

For Y axis , axis number is 1

For Z axis, axis number is 2

For W axis, axis number is 3

Example: The signals of MNEL503 axis DRO RS – 232 output port.

0: 26.610

1: 6638.425

2: -42.890

IES ELEKTRONIK MAKINA SAN. IC ve DIS TIC. LTD.

Istanbul - TURKEY

 Tel +90 (212) 4834011

 Fax +90 (212) 4834012

 Web www.ies.com.tr

 E-Mail info@ies.com.tr

Official dealer BENELUX

Trabiss International

Kruiswijk 19P

1761 AR, Anna Paulowna, Holland

 Tel +31 (0) 223 523490

 Web www.trabiss-metrology.com

 E-Mail info@trabiss-int.com

MNEL500.EN.2023